

ABE – DIN-7504-K



ABEI – DIN 7504-K A2



ARE – DIN-7504-K RE



AUTO

CHARACTERISTICS

- Drill point: drill material directly – no need for pre-drilled hole.
- Self-tapping thread.
- Wide variety of head types, diameters and lengths for different applications: flexibility in installation.
- Zinc plated coatings, available in different coatings upon request.
- Versions in standard commercial lacquered plate colours (RAL colour scheme).
- Coloured caps available for hexagonal heads.

APPLICATIONS

- For joining metal to wood, joining metallic elements, or plastic, wood or other materials on metallic materials.
- Versions with galvanized steel-EPDM or stainless steel-EPDM washer for sealed joints in façades and roofing, in different diameters.





BASE MATERIALS



APPLICATION EXAMPLES



1.RANGE

ITEM	DENOMINACION	PHOTO	REGULATION	HEAD	SOCKET	ØEPDM WASHER (1)	MATERIAL COATING (2) (3)	MATERIAL TO BE FIXED
1	ABE DIN-7504-K		DIN 7504K	Hexagonal with washer	---	14, 16, 18, 25	Steel / Zinc-plated	Steel
2	ABEI DIN-7504-K-A2		DIN 7504K	Hexagonal with washer	---	---	Stainless Steel	Aluminium
3	ARE DIN-7504-K RE		---	Hexagonal with washer	---	16, 18, 25	Steel / Zinc-plated	Steel
4	AUTO		---	Hexagonal with washer	---	16	Steel / Zinc-plated	Steel

(1) EPMD washer characteristics according to ARVUL Data Sheet.

(2) Coatings:
Zinc-plated $\geq 3 \mu\text{m}$ according to ISO 4042 A1J
Black zinc-plated $\geq 3 \mu\text{m}$ according to ISO 4042 A1N

(3) Available in various coatings and colours upon request.

MATERIALS

Characteristic	ABE - ABEI - ARE - AUTO
Material	Special steel for SAE J403 1022 thermal treatment
Surface hardness	> 500 HV
Core hardness	240 - 450 HV
Depth hardness	ST 2.5 – 3.5: 0.05 – 0.18 mm. ST 3.9 – 5.5: 0.10 – 0.23 mm. ST 6.3: 0.15 – 0.28 mm.

POINT SELECTION

The choice of screw point must be such that the total thickness of materials to be joined (including any intermediate spaces) is lower than the edge of the drill point; otherwise screw breakage may occur during installation.

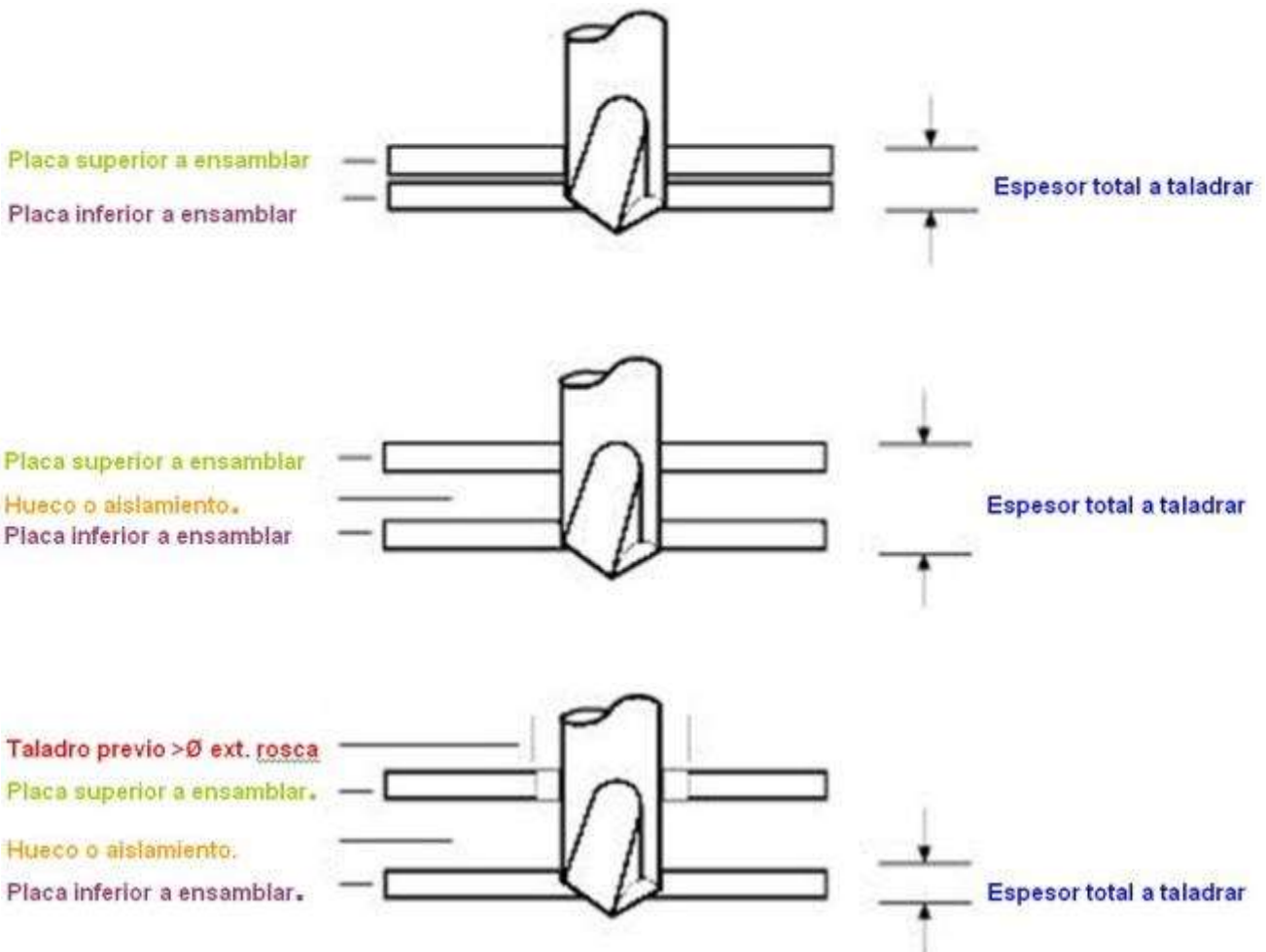

INSTALLATION PARAMETERS

Parameter		ST 3.5	ST 3.9	ST 4.2	ST 4.8	ST 5.5 M 5.5	ST 6.3
Maximum installation strength	[N]	150	200	250	250	350	350
Drill Speed	Steel	[rpm] 1800 - 2500				1000 - 1800	
	Stainless Steel	[rpm] 1000 - 1500				600 - 1000	
Maximum time	[sg]	4	4.5	5	7	11	13
Maximum torque	[Nm]	2.8	3.8	4.7	6.9	10.4	16.9

10 N ≈ 1 Kg

10 Nm ≈ 1Kg m

With high drilling times or excessive drilling speed there is a risk of burning the drill bit and therefore not drilling the material.

SCREW	ØTHREAD	THICKNESS TO BE FIXED IN STEEL [mm]	
AUTO	5.5	4.0	12.0

ABE ABEI	6.3		2,5	6,0
	5.5		1,75	5,25
	4.8		1,75	4,4
	4.2		1,75	3,0
	3.9	0,7	2,4	
	3.5	0,7	2,25	

ARE	6.3		1.0	1.5
	5.5		1.0	1.5
	4.8	0.3	1.0	

0,00 0,25 0,50 0,75 1,00 1,25 1,50 1,75 2,00 2,25 2,50 2,75 3,00 3,25 3,50 3,75 4,00 4,25 4,50 4,75 5,00 5,25 5,50 5,75 6,00 6,5 7,0 7,5 8,0 8,5 9,0 9,5 10,0 10,5 11,0 11,5 12,0

MAXIMUM THICKNESS TO BE FIXED						
Length	ST 3,5	ST 3,9	ST 4,2	ST 4,8	ST 5,5	ST 6,3
9,5	2,85					
11	4,2					
13	6,2	5,8	4,3	3,7		
16	9,2	8,8	7,3	5,5		
19	12,1	11,7	10,3	8,7	8,7	7
22	15,1	14,7	13,3	11,7	11,7	10
25	18,1	17,7	16,3	14,7	14,7	13
32	25,1	24,5	23	21,5	21,5	20
38		30,5	29	27,5	27,5	26
45			36	34,5	34,5	33
50			41	39,5	39,5	38
60				49,5	49,5	48
63				52,5	52,5	51
73				62,5	62,5	61
75				64,5	64,5	63
80				69,5		68
90				79,5		78
100				89,5		88
110						98
120						108
130						118
140						128

SCREW RESISTANCE CHARACTERISTICS*

SIZE	TENSION [kN]	SHEAR [kN]
ST 2.9	2.62	1.31
ST 3.5	3.81	1.91
ST 3.9	4.64	2.32
ST 4.2	5.26	2.63
ST 4.8	7.11	3.56
ST 5.5	9.63	4.82
ST 6.3	13.36	6.68

1 kN ≈ 100 Kg

For tension loads, the inherent resistance of plates to be fixed must be taken into account, which is usually less than the resistance of the screw itself, as the screw will probably tear the plates.

RECOMMENDED TENSION LOAD IN STEEL PLATE

SIZE	RECOMMENDED LOAD					
	e[mm]	N[kN]	e[mm]	N[kN]	e[mm]	N[kN]
ST 3.5	0.8	0.55	1.5	0.89	2.0	1.13
ST 3.9	0.8	0.54	1.5	0.97	2.0	1.50
ST 4.2	2.0	1.63	2.5	1.51	3.0	2.62
ST 4.8	2.0	1.87	3.0	2.77	4.0	3.71
ST 5.5	2.0	1.77	3.5	2.86	5.0	3.43
ST 6.3	2.5	1.44	4.0	3.19	5.0	4.83

RECOMMENDED TENSION LOAD IN ALUMINIUM PLATE

SIZE	RECOMMENDED LOAD					
	e[mm]	N[kN]	e[mm]	N[kN]	e[mm]	N[kN]
ST 4.8	2.0	0.95	3.0	1.52	4.0	2.10

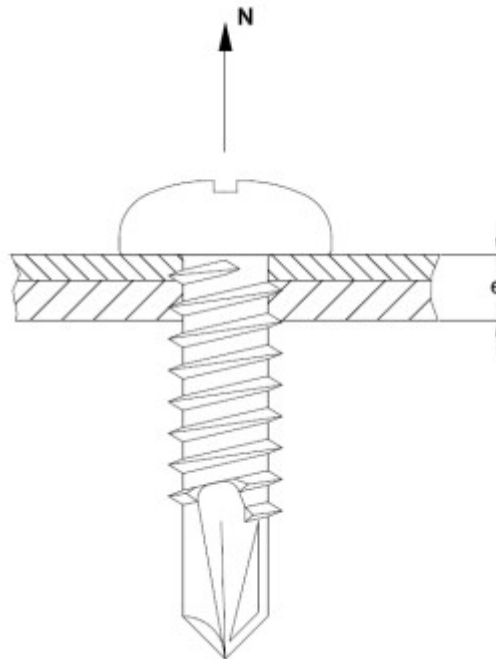

2. INSTALLATION DATA

2.1 – ABE – DIN 7504-K

Self-drilling screw - hexagonal head with embossed washer

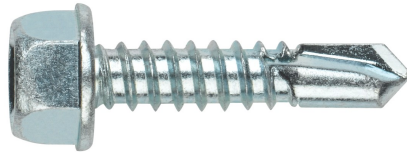

Properties



Steel



Zinc-plated coating



Available in different colours

Base material

Properties



Plate assembly



Plate profile



Hexagonal with embossed washer

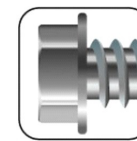

Hexagonal with embossed washer



Screw point

Installation data

CODE		ST 3.5	ST 4.2	ST 4.8	ST 5.5	ST 6.3
dk: washer head diameter	[mm]	8	8.5	10	10.5	12.6
k: head thickness	[mm]	3.3	4.1	4.3	4.3	6.3
c: washer thickness	[mm]	1.2	1.5	1.6	1.9	2
s: spanner	[mm]	6	7	8	8	10
D: exterior thread diameter	[mm]	3.53	4.22	4.80	5.46	6.25
d: interior thread diameter	[mm]	2.64	3.10	3.58	4.17	4.88
p: thread	[mm]	1.3	1.4	1.6	1.8	1.8
l: lengths	[mm]	9.5 - 32	13 - 38	13 - 38	19- 75	19 - 240
Installation bit code (hexagonal magnetic bit)		BOCA006	BOCA007	BOCA008	BOCA008	BOCA010
Drill capacity	[mm]	0.70 - 2.25	1.75 - 3.00	1.75 - 4.40	1.75 - 5.25	2.50 - 6.00

DRAWING

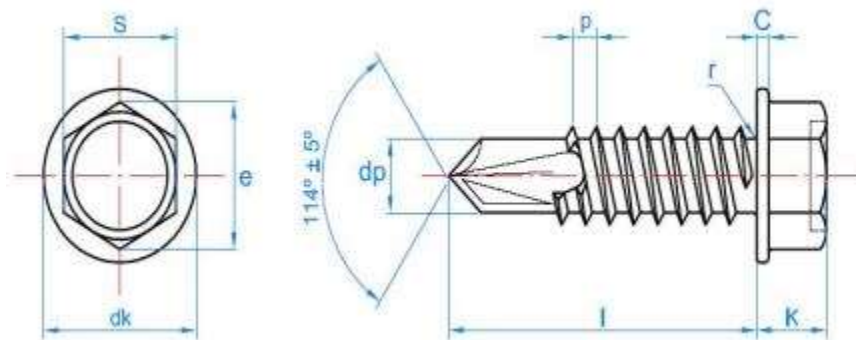

- Zinc-plated finish.
- For general plate-plate joints.
- Versions with assembled EPMD washer for sealed joints in façades and roofing (consult ARVUL Technical Data Sheet).

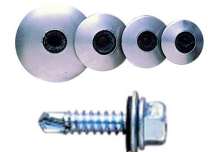

2.2 – ABEI - DIN-7504-K A2

Self-drilling screw - hexagonal head with embossed washer Stainless Steel A2



Properties



Stainless Steel A2

Base material

Properties

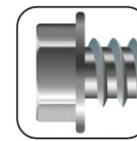

Plate assembly

Plate profile

Aluminium

Hexagonal with embossed washer

Hexagonal with embossed washer

Reduced screw point

Installation data

CODE		ST 4.2	ST 4.8	ST 5.5	ST 6.3
d _k : washer head diameter	[mm]	8.5	10	10.5	12.6
k: head thickness	[mm]	4.1	4.3	4.3	6.3
c: washer thickness	[mm]	1.5	1.6	1.9	2
s: spanner	[mm]	7	8	8	10
D: exterior thread diameter	[mm]	4.22	4.80	5.46	6.25
d: interior thread diameter	[mm]	3.10	3.58	4.17	4.88
p: thread	[mm]	1.4	1.6	1.8	1.8
l: lengths	[mm]	13 - 38	13 - 38	19- 75	19 - 140
Installation bit code (hexagonal magnetic bit)		BOCA007	BOCA008	BOCA008	BOCA010
Drill capacity	[mm]	1.75 - 3.00	1.75 - 4.40	1.75 - 5.25	2.50 - 6.00

DRAWING

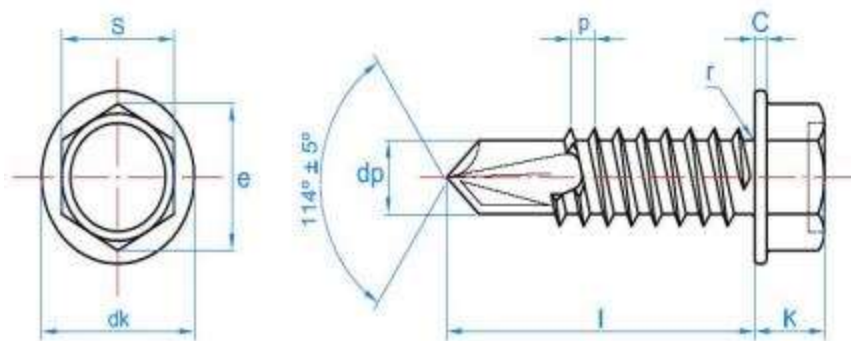

- Stainless Steel A2.
- For general plate-plate joints made of aluminium.

2.3 – ARE – DIN-7504-K RE

Self-drilling screw with reduced point and 8mm hexagonal head

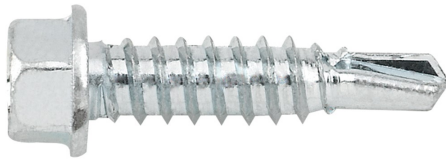

Properties



Steel



Zinc-plated coating



Available in different colours

Base material

Properties



Plate assembly



Plate profile



Aluminium



Hexagonal with embossed washer

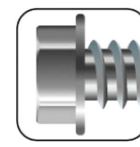

Hexagonal with embossed washer



Reduced screw point

Installation data

CODE		ST 4.8	ST 5.5	ST 6.3
dk: washer head diameter	[mm]	11	11	11
k: head thickness	[mm]	4.45	5.45	5.45
c: washer thickness	[mm]	1.15	1.25	1.25
s: spanner	[mm]	8	8	8
D: exterior thread diameter	[mm]	4.80	5.46	6.25
d: interior thread diameter	[mm]	3.58	4.17	4.88
p: thread	[mm]	1.6	1.8	1.8
l: lengths	[mm]	16 - 19	22	20 - 80
Installation bit code (hexagonal magnetic bit)		BOCA008	BOCA008	BOCA008
Maximum drill capacity	[mm]	0.0 - 1.0	1.0 - 1.5	1.0 - 1.5

DRAWING

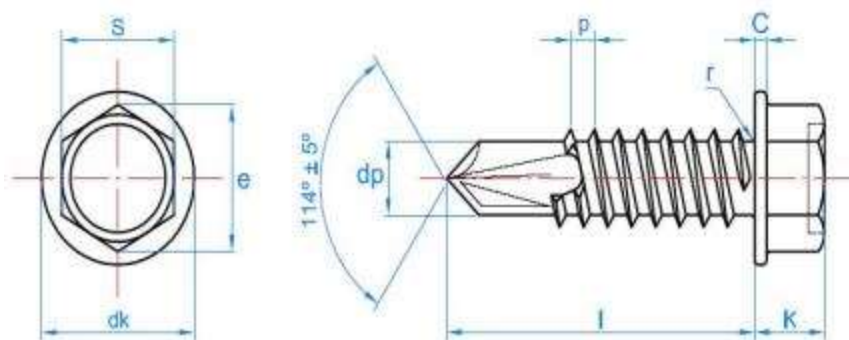

- Zinc-plated finish.
- Low thickness plate-plate joints, up to 1.5 mm. The point performs a prior drill-hole with a smaller diameter. The thread, with a greater diameter, creates an extrusion in the plate, lengthening and strengthening the threaded area.
- Drill following the upper part of the rpm range from the table in section 5.
- Versions with assembled EPDM washer for sealed joints in façades and roofing (consult ARVUL Technical Data Sheet).



2.4 - AUTO

**Self-drilling screw for girders - screw point no.5
- hexagonal head**



Properties



Steel



Zinc-plated coating



Available in different colours

Base material

Properties



Plate assembly



Plate profile

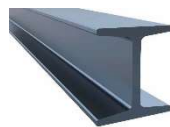

IPN



Hexagonal with embossed washer

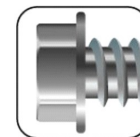

Hexagonal with embossed washer



Girder screw point

Installation data

CODE		M 5.5
d _k : washer head diameter	[mm]	11
k: head thickness	[mm]	5.3
c: washer thickness	[mm]	1.15
s: spanner	[mm]	8
Point		#5
D: exterior thread diameter	[mm]	5.5
d: interior thread diameter	[mm]	4.6
p: thread	[mm]	1.06
l: lengths	[mm]	32 - 38
Installation bit code (hexagonal magnetic bit)		BOCA008
Drill capacity	[mm]	4.0 – 12.0

DRAWING

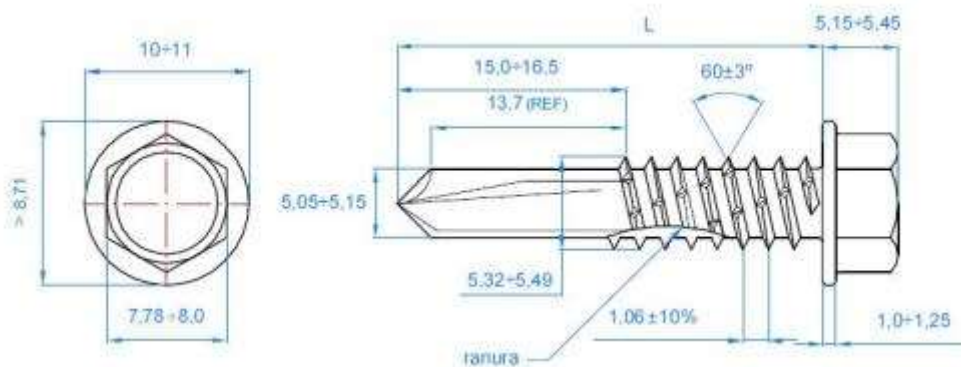

- Zinc-plated finish.
- For general plate-plate joints for thicknesses up to 12 mm.
- Versions with assembled EPDM washer for sealed joints in façades and roofing (consult ARVUL Technical Data Sheet).

