

TR-13

TR-15

TR-BL

CHARACTERISTICS

Inspection panels for drywall.

Size range: from 200x200 till 600x600. For different sizes please contact sales department.

Opening by pushing the panel's door, it gets closed by pushing locks.

The door can be disassembled in order to facilitate installation.

Storage and preservation over flat surfaces, the place should be protected from sun and raining.

- TR-13/15:
 - Aluminum frame inspection panel with green drywall plate waterproof.
 - Served with bag of screw y plugs for its own installation.
 - Served in cardboard box that protects the product.
 - Retaining element once the door is opened.
- TR-BL:
 - White galvanized sheet inspection panel (RAL 9016).
 - It has 4 flanges allowing the fixation to the supporting element.
 - Served in retractable film that protects the product.
 - The door rotates around spin axis with elastic spring.

Application: mainly used in drywall and ceilings.

APPLICATION USE



1. RANGE

ITEM	CODE	SIZES	PHOTO	MATERIAL
1	TR-13	From 200 x 200 mm till 600 x 600 mm		Aluminum frame with waterproof drywall plate of 12,5 mm.
2	TR-15	From 200 x 200 mm till 600 x 600 mm		Aluminum frame with waterproof drywall plate of 15 mm.
3	TR-BL	From 200 x 200 mm till 600 x 600 mm		White galvanized steel RAL 9016

2. INSTALLATION DATA

2.1 TR-13

Inspection panel for drywall 13 mm thickness

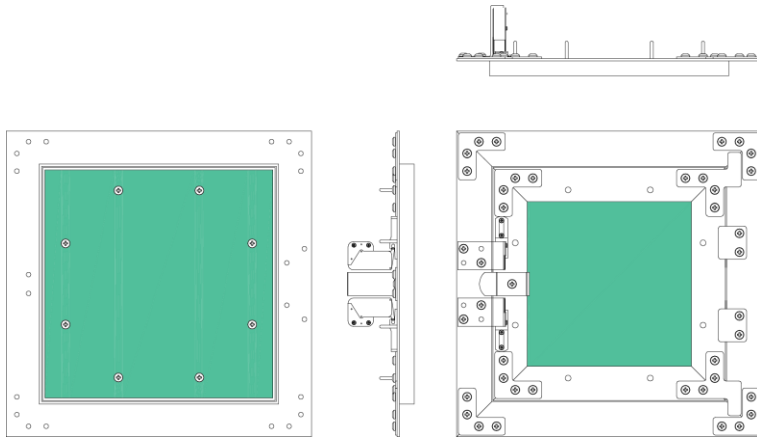

MATERIALS & GEOMETRY



Aluminum frame



Waterproof drywall

CHARACTERISTICS

- Removable
- Drywall 12.5 mm thickness
- Plugs for the screws included
- Closing by pushing locks

CODE	A	B	C	D	Uds./KIT
TR13200200	200	199	204	260	2
TR13300300	300	299	304	360	2
TR13400400	400	399	404	460	2
TR13500500	500	499	504	560	1
TR13600600	600	599	604	660	1

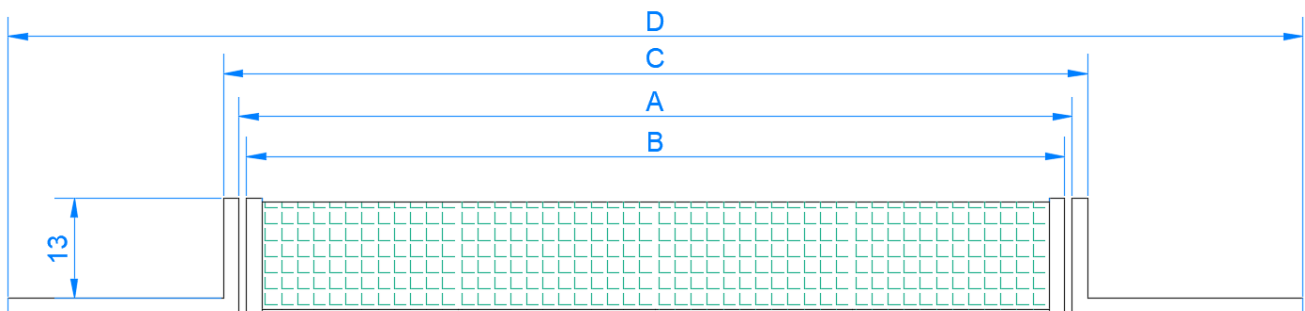

2.2 TR-15

Inspection panel for drywall 15 mm thickness

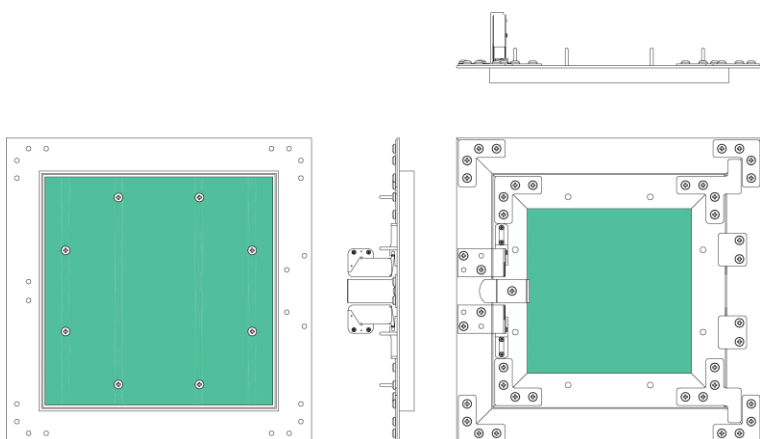

MATERIALS & GEOMETRY



Aluminum frame

Waterproof drywall

CHARACTERISTICS

- Removable
- Drywall 15 mm thickness
- Plugs for the screws included
- Closing by pushing locks

CODE	A	B	C	D	Uds./KIT
TR15200200	200	199	204	260	2
TR15300300	300	299	304	360	2
TR15400400	400	399	404	460	2
TR15500500	500	499	504	560	1
TR15600600	600	599	604	660	1

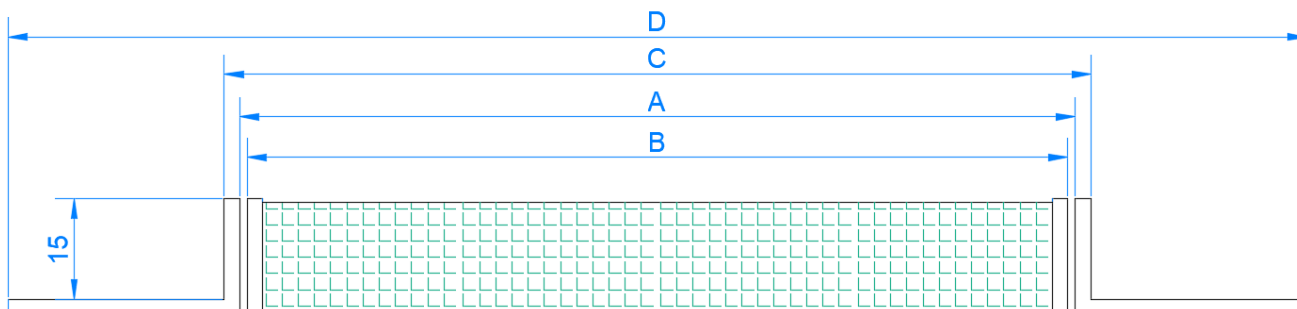

2.3 TR-BL

White inspection panel for drywall

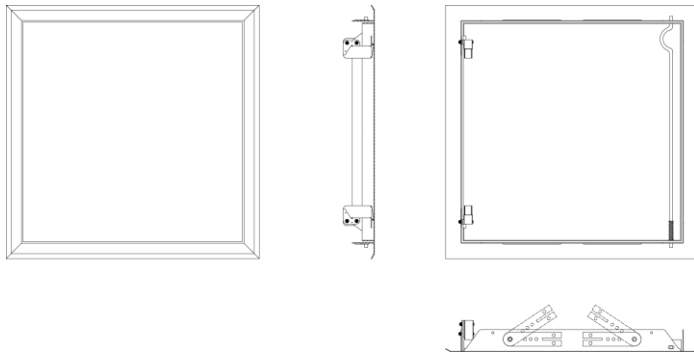

MATERIALS & GEOMETRY



Steel frame



White lacquered galvanized steel (RAL 9016)

CHARACTERISTICS

- Removable
- 4 fixing flanges
- Closing by pushing locks

CODE	A	B	C	D	Uds./KIT
TRBL200200	195	193	197	235	1
TRBL300300	295	293	297	335	1
TRBL400400	395	393	397	435	1
TRBL500500	495	493	497	535	1
TRBL600600	595	593	597	635	1

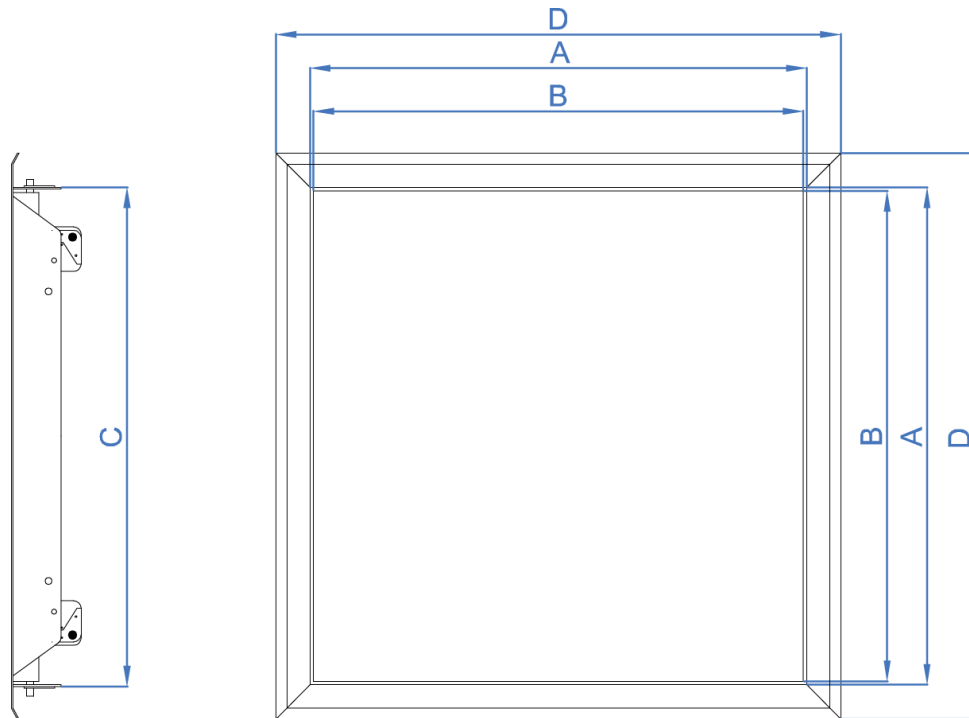

3. INSTALLATION PROCEDURE

3.1. TR-13 / TR-15

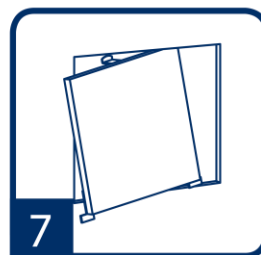
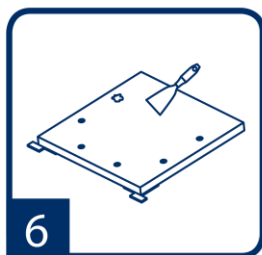
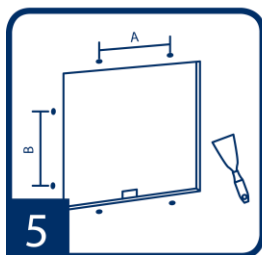
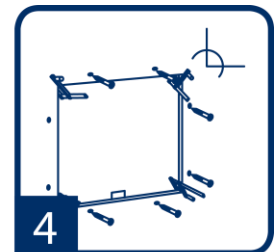
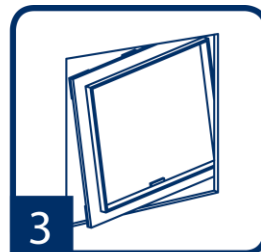
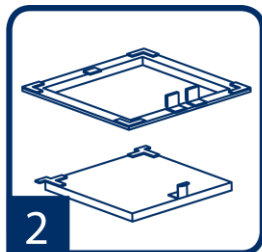
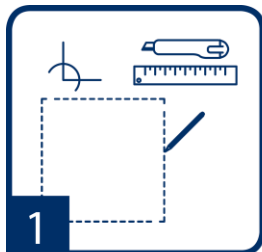

1. DRAW & CUT

Draw the area used by the inspection panel once it is installed, you can use a template or use the inspection panel itself. Once the area is drawn proceed to cut the panel.

2. REMOVE THE DOOR

Remove the door of the inspection panel, push the door. After the door is opened push down the safety flange in order to disassemble the door.

3. ENTER THE FRAME

Enter the aluminum frame in the hollow cut in step 1. Tilt the frame to take advantage of the longest length between vertexes.

4. HOLD & MARK

With the aluminum frame inside the panel, fix it to the drywall using clamps. Mark the screwing points. (see step 5)

5. FIX THE FRAME

Fix the frame to the drywall with self-drilling screws, use screws suitable for this material. Fix them in the points marked in step 4. These distances A & B should be always ≤ 150 mm.

6. SEAL & PAINT

Seal the screw heads once the frame has been fixed. Seal the screws of the door and paint the door's panel. Do it always with the door disassembled.

7. PLACE

Enter the door inside the hollow left by the frame.

8. CLOSE

After put it in position push the flange to its starting position and push the door to close the inspection panel.

3.2.1 TR-BL OPTION 1

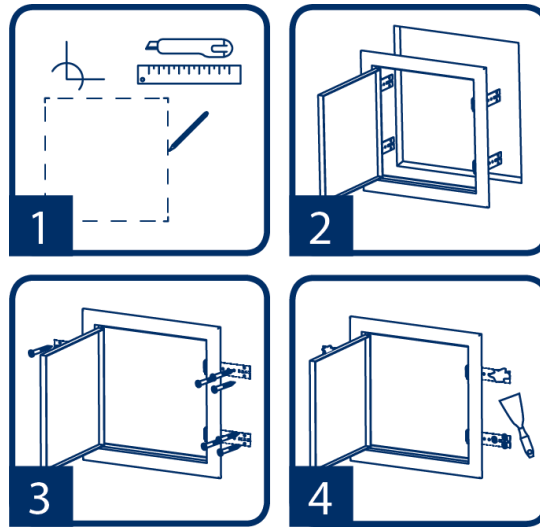

1. DRAW & CUT

Draw the area used by the inspection panel once it is installed, you can use a template or use the inspection panel itself. Once the area is drawn proceed to cut the panel.

2. HOLD THE DOOR

Hold the door in the hollow cut in step 1. When the inspection panel is in position, bend the flanges. Make sure that the drywall is between the frame and the flanges. Mark the points of drilling.

3. FIX THE FRAME

Fix the frame to the drywall with self-drilling screws, use screws suitable for this material. Fix them in the points marked.

4. SEAL & CLOSE

Seal the screw heads used to fix the frame and paint it. Push the door to close it completely.

3.2.2 TR-BL OPTION 2

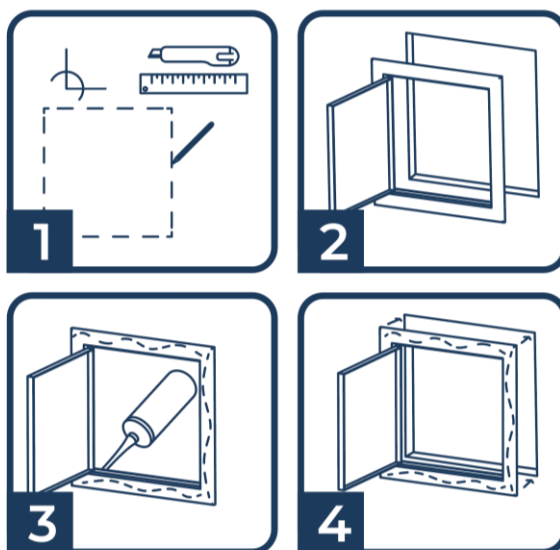

1. DRAW & CUT

Draw the area used by the inspection panel once it is installed, you can use a template or use the inspection panel itself. Once the area is drawn, proceed to cut the panel.

2. CHECK THE HOLLOW FOR THE DOOR

Place the door in position to check that it fits correctly, then remove it.

3. APPLY THE ADHESIVE

Apply an adhesive, such as MS-PR, around the entire inner edge of the door, leaving the flanges in their initial position as they will not be used in this type of installation.

4. PLACE AND LEAVE TO CURE

Place the door in the hollow with the adhesive applying pressure and leave to cure for the time specified by the adhesive.