



TB



INVZ



TBA2



INVN



TBR



INVA2



ESTRINVZ

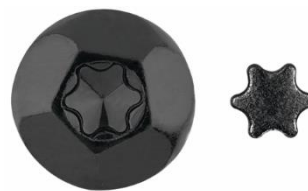

ESTRINVN

CHARACTERISTICS

- Approved according to **CE** EN 14592:2008+A1:2012 standard for load bearing timber structures.
- Use in all type of wooden carpentry.
- Zinc plated and stainless steel AISI 304 **A2** inox
- Hexagonal head and tamperproof Tx versions.
- In TB screw the minimum tread length is 60% of the total length of the screw.

APPLICATIONS

- Applications TB: Fixing ironworks to wood, union of load bearing timber structures, union of metallic reinforcement to wood, load bearing timber structures.
- Applications INV: Installation of fences, bars, handrails, urban furniture, etc., where a tamperproof screw is needed.
- Apt for use with nylon plug.

BASE MATERIAL



Pinewood



Thin wood

For highly hard and dense woods (approximately higher than 550 kg/m3) it is recommended to make a pre-drill to facilitate installation.



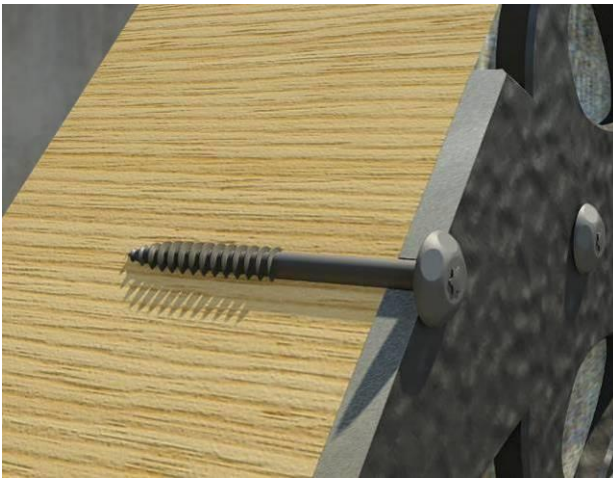















APPLICATION EXAMPLES



MATERIALS

CODE	MATERIAL	COATING
INVZ, TB, TBR	TB: Steel class 4.8 s/ ISO 898-1	Zinc $\geq 5 \mu\text{m}$ ISO 4042 A2J
INVN		Black zinc $\geq 5 \mu\text{m}$ ISO 4042 A2N
TBA2, INVA2	Stainless steel A2	---

1. SELECTION CHART

Screw	Head	Tip	Thread	Pitch	Coating	Approvals
INVZ	 Tamperproof	C	Wood 60°	Tx 40	 Zinc	
INVN	 Tamperproof	C	Wood 60°	Tx 40	 Black zinc	
INVA2	 Tamperproof	C	Wood 60°	Tx 40	 Stainless A2	
TB	 Hexagonal	C	Wood 60°	---	 Zinc	
TBA2	 Hexagonal	C	Wood 60°	---	 Stainless A2	
TBR	 Hexagonal	C	Wood 60°	---	 Zinc	

2. INSTALLATION DATA

2.1 TB COACH SCREW DIN-571



Main use



Properties



Steel



Zinc coating

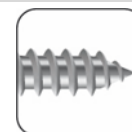

Self-tapping
C tip

Properties



Installation with drill
/screwdriver



Hexagonal

Characteristics and advantages

- Zinc coating > 5 µm
- Hexagonal head
- 60° thread
- C tip
- Application: Ironworks previously drilled to wood (Apt use with nylon plug)

Code		TB05	TB06	TB07	TB08	TB10	TB12	TB14
s: Head diameter	[mm]	8	10	12	13	17	19	22
D: Outer thread diameter	[mm]	5	6	7	8	10	12	14
d: Inner thread diameter	[mm]	3.5	4.2	4.9	5.6	7.0	9.0	10.5
p: Pitch	[mm]	2.2	2.6	3.2	3.5	4.5	5.0	5.5
k: Head thickness	[mm]	3.5	4.0	5.0	5.5	7.0	8.0	9.0
l: Screw length	[mm]	30 - 60	25 - 120	30 - 120	30 - 200	40 - 200	60 - 260	100
Hexagon dopbit code	[-]	BOCA008	BOCA010	---	BOCA013	---	---	---

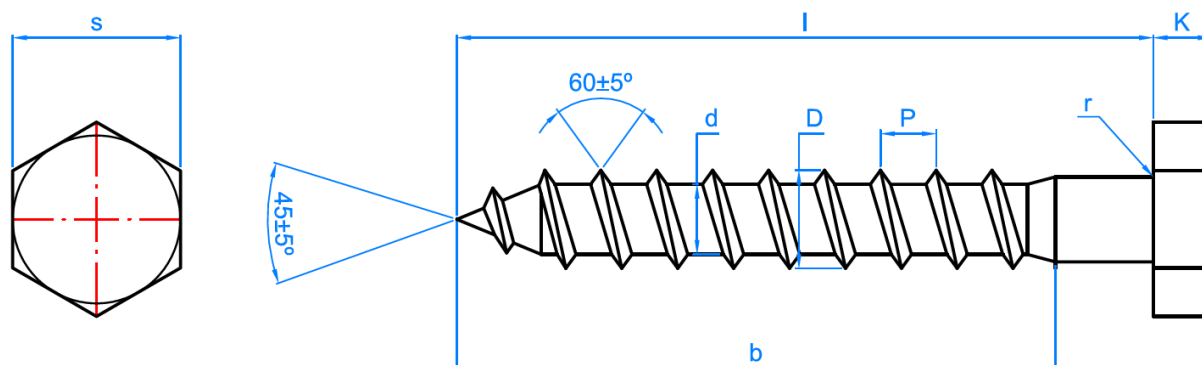

TECHNICAL CHARACTERISTICS									
Essential characteristics	Version	Performance							
		Unit	Ø 5	Ø 6	Ø 7	Ø 8	Ø 10	Ø 12	Ø 14
Characteristic yield moment $M_{y,k}$	Zinc	[Nmm]	5984	10749	18047	24131	49056	81096	129198
Characteristic withdrawal parameter $f_{ax,k}$ with $\rho_k = 450 \text{ kg/m}^3$	Zinc	[N/mm ²]	9,31	7,73	10,33	6,72	6,71	7,62	7,05
Characteristic head pull-through parameter $f_{head,k}$ with $\rho_k = 450 \text{ kg/m}^3$	Zinc	[N/mm ²]	26,42	24,90	24,74	22,55	21,37	20,15	20,23
Characteristic tensile capacity $f_{tens,k}$	Zinc	[kN]	5,20	7,40	9,10	11,80	18,90	34,20	45,20
Characteristic torsion ratio with $\rho_k = 450 \text{ kg/m}^3$	Zinc	[--]	4,56	6,88	14,07	19,24	40,13*	74,61*	121,20*
Characteristic torsional resistance into timber $R_{tor,k}$	Zinc	[--]	1,31	2,82	4,89	7,85	13,08*	20,96*	34,74*
Corrosion protection	Zinc	[--]	Service class 2 according to EN 1995-1-1						
(*) Predrilled									
Coordinated technical specification: EN 14592:2008 + A1:2012									

2.2 TBA2

Coach screw DIN-571 A2



Steel



AISI 304

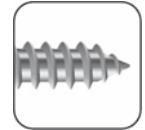

Self-tapping
C tip

Main use



Properties



Installation with drill
/screwdriver



Hexagonal

Characteristics and advantages

- Stainless A2
- Hexagonal head
- 60° thread
- Use outdoors
- C tip
- Application: Ironworks previously drilled to wood:
(Apt for use with nylon plug)

Code		TBA206	TBA208	TBA210
s: Head diameter	[mm]	10	13	17
D: Outer thread diameter	[mm]	6	8	10
d: Inner thread diameter	[mm]	4.2	5.6	7.0
p: Pitch	[mm]	2.6	3.5	4.5
k: Head thickness	[mm]	4.0	5.5	7.0
l: Screw length	[mm]	40 – 70	50 – 80	80
Hexagon dopbit code	[-]	BOCA010	BOCA013	---

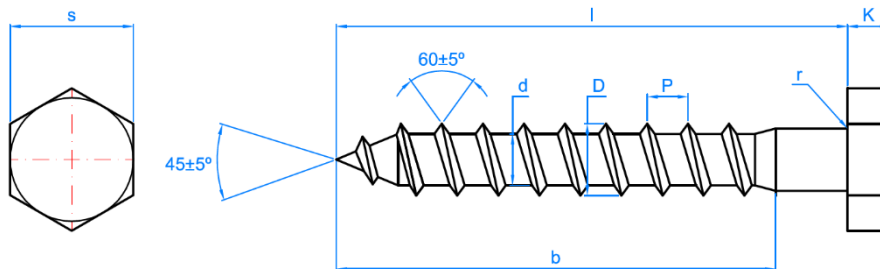

TECHNICAL CHARACTERISTICS					
Essential characteristics	Version	Performance			
		Unit	Ø 6	Ø 8	Ø 10
Characteristic yield moment $M_{y,k}$	Stainless A2	[Nmm]	14180	29081	41348
Characteristic withdrawal parameter (along fibre) $f_{ax,k}$ with $\rho_k = 450 \text{ kg/m}^3$	Stainless A2	[N/mm ²]	13,24	12,43	12,23
Characteristic withdrawal parameter (across fibre) $f_{ax,k}$ with $\rho_k = 450 \text{ kg/m}^3$	Stainless A2	[N/mm ²]	8,00	7,30	8,68
Characteristic head pull-through parameter $f_{head,k}$ with $\rho_k = 450 \text{ kg/m}^3$	Stainless A2	[N/mm ²]	24,77	22,25	20,76
Characteristic traction capacity $f_{tens,k}$	Stainless A2	[kN]	12,81	18,55	30,12
Characteristic torsion ratio with $\rho_k = 450 \text{ kg/m}^3$	Stainless A2	[-]	3,75	5,04	4,80*
Corrosion protection	Stainless A2	[N/mm ²]	Service class 3 according to EN 1995-1-1		
(*) Predrilled					
Coordinated technical specification: EN 14592:2008 + A1:2012					

2.3 TBR

571 TR Coach screw



Properties



Steel



Zinc coating

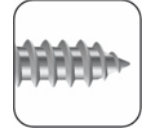

Self-tapping
C tip

Main use



Properties



Installation with drill
/screwdriver

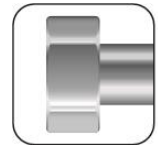

Hexagonal

Characteristics and advantages

- Zinc coating > 5 µm
- hexagonal head
- 60° thread
- C tip
- Complete thread
- Application: Ironworks previously drilled to wood: (Apt for use with nylon plug)

Code		TBR06	TBR08	TBR10
s: Head diameter	[mm]	10	13	17
D: Outer thread diameter	[mm]	6	8	10
d: Inner thread diameter	[mm]	4.2	5.6	7.0
p: Pitch	[mm]	2.6	3.5	4.5
k: Head thickness	[mm]	4.0	5.5	7.0
l: Screw length	[mm]	50 - 70	50 - 80	60 - 80
b: thread length	[mm]	Complete	Complete	Complete
Hexagon dopbit code	[-]	BOCA010	BOCA013	---

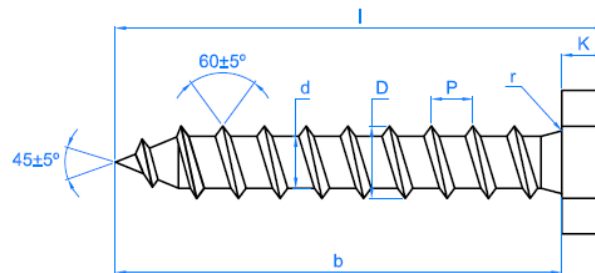
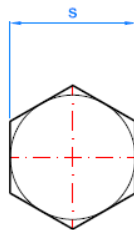

TECHNICAL CHARACTERISTICS					
Essential characteristics	Version	Performance			
		Unit	Ø 6	Ø 8	Ø 10
Characteristic yield moment $M_{y,k}$	Zinc	[Nmm]	10749	24131	49056
Characteristic withdrawal parameter (along fibre) $f_{ax,k}$ with $\rho_k = 450 \text{ kg/m}^3$	Zinc	[N/mm ²]	14,74	13,38	10,58
Characteristic withdrawal parameter (across fibre) $f_{ax,k}$ with $\rho_k = 450 \text{ kg/m}^3$	Zinc	[N/mm ²]	7,73	6,72	6,71
Characteristic head pull-through parameter $f_{head,k}$ with $\rho_k = 450 \text{ kg/m}^3$	Zinc	[N/mm ²]	24,90	22,55	21,37
Characteristic traction capacity $f_{tens,k}$	Zinc	[kN]	7,40	11,80	18,90
Characteristic torsion ratio with $\rho_k = 450 \text{ kg/m}^3$	Zinc	[--]	2,44	2,45	3,07*
Corrosion protection	Zinc	[--]	Service class 2 according to EN 1995-1-1		
(*) Predrilled Coordinated technical specification: EN 14592:2008 + A1:2012					

2.4 INVZ

Coach tamperproof screw



Main use



Properties



Steel



Zinc coating

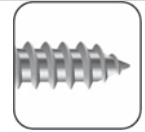

Self-tapping
C tip

Properties



Installation with drill
/screwdriver

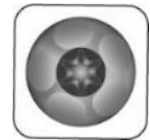

Tamperproof

Characteristics and advantages

- Zinc coating > 5 µm
- Special tamperproof head
- 60° thread
- C tip
- Hexalobular torque (Tx) ISO 10664 nº 40.
- Comes with a tamperproof hexalobular Tx recess 40 to put on torque once installed.
- Application: Ironworks previously drilled to wood: (Apt for use with nylon plug)

Code		INVZ6	INVZ7
∅B: Head diameter	[mm]	10	12
D: Outer thread diameter	[mm]	6	7
d: Inner thread diameter	[mm]	4.2	4.9
p: Pitch	[mm]	2.6	3.2
E: Head thickness	[mm]	4.4	4.4
l: Screw length	[mm]	40 - 70	30 - 90
Screwing tip	[-]	PUTO040	PUTO040

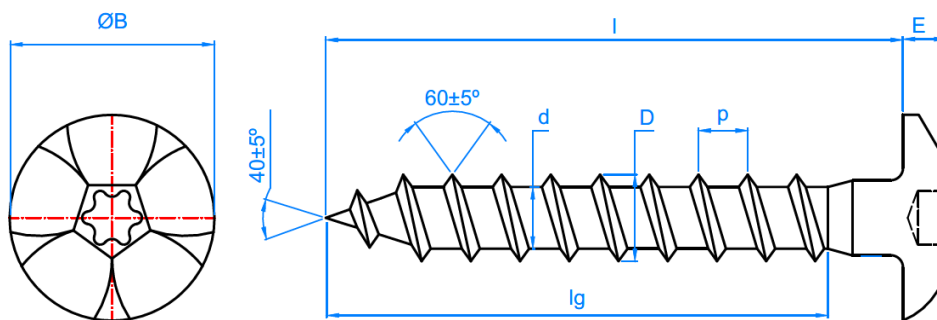

Technical characteristics				
Essential characteristics	Version	Performance		
		Unit	Ø 6	Ø 7
Characteristic yield moment $M_{y,k}$	Zinc	[Nmm]	10749	18047
Characteristic withdrawal parameter (along fibre) $f_{ax,k}$ with $\rho_k = 450 \text{ kg/m}^3$	Zinc	[N/mm ²]	14,74	14,36
Characteristic withdrawal parameter (across fibre) $f_{ax,k}$ with $\rho_k = 450 \text{ kg/m}^3$	Zinc	[N/mm ²]	7,73	10,33
Characteristic head pull-through parameter $f_{head,k}$ with $\rho_k = 450 \text{ kg/m}^3$	Zinc INV	[N/mm ²]	19,43	19,39
Characteristic traction capacity $f_{tens,k}$	Zinc	[kN]	7,40	9,10
Characteristic torsion ratio with $\rho_k = 450 \text{ kg/m}^3$	Zinc	[--]	2,44	2,88
Corrosion protection	Zinc	[--]	Service class 2 according to EN 1995-1-1	

2.5 INVN

Black tamperproof coach screw



Main use



Properties



Steel



Black zinc coating

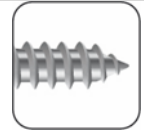

Self-tapping
C tip

Properties



Installation with drill
/screwdriver

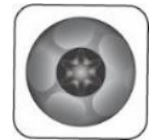

Tamperproof

Characteristics and advantages

- Black zinc coating > 5 µm
- Special tamperproof head
- 60° thread
- C tip
- Hexalobular torque (Tx) ISO 10664 nº 40.
- Comes with a tamperproof hexalobular Tx recess 40 to put on torque once installed.
- Application: Ironworks previously drilled to wood: (Apt for use with nylon plug)

Code		INVZ6	INVZ7
∅B: Head diameter	[mm]	10	12
D: Outer thread diameter	[mm]	6	7
d: Inner thread diameter	[mm]	4.2	4.9
p: Pitch	[mm]	2.6	3.2
E: Head thickness	[mm]	4.4	4.4
l: Screw length	[mm]	40 - 70	30 - 90
Screwing tip	[-]	PUTO040	PUTO040

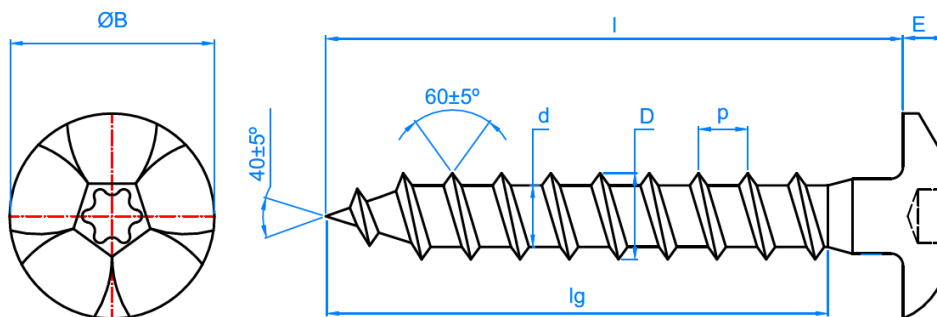

TECHNICAL CHARACTERISTICS				
Essential characteristics	Version	Performance		
		Unit	Ø 6	Ø 7
Characteristic yield moment $M_{y,k}$	Zinc	[Nmm]	10749	18047
Characteristic withdrawal parameter (along fibre) $f_{ax,k}$ with $\rho_k = 450 \text{ kg/m}^3$	Zinc	[N/mm ²]	14,74	14,36
Characteristic withdrawal parameter (across fibre) $f_{ax,k}$ with $\rho_k = 450 \text{ kg/m}^3$	Zinc	[N/mm ²]	7,73	10,33
Characteristic head pull-through parameter $f_{head,k}$ with $\rho_k = 450 \text{ kg/m}^3$	Zinc INV	[N/mm ²]	19,43	19,39
Characteristic traction capacity $f_{tens,k}$	Zinc	[kN]	7,40	9,10
Characteristic torsion ratio with $\rho_k = 450 \text{ kg/m}^3$	Zinc	[--]	2,44	2,88
Corrosion protection	Zinc /black	[--]	Service class 2 according to EN 1995-1-1	

2.6 INVA2

Stainless tamperproof coach screw



Main use



Properties



Steel



AISI 304

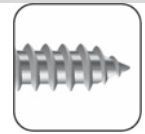

Self-tapping
C tip

Properties



Installation with drill
/screwdriver

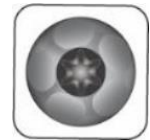

Tamperproof

Characteristics

- Stainless finish
- Special tamperproof head
- 60° thread
- Hexalobular torque (Tx) ISO 10664 nº 40.

- Use outdoors
- C tip
- Application: Ironworks previously drilled to wood: (Apt for use with nylon plug)

Code		TB07
∅B: Head diameter	[mm]	12
D: Outer thread diameter	[mm]	7
d: Inner thread diameter	[mm]	4.9
p: Pitch	[mm]	3.2
E: Head thickness	[mm]	4.4
l: Screw length	[mm]	50 - 80
Screwing tip	[-]	PUTO040

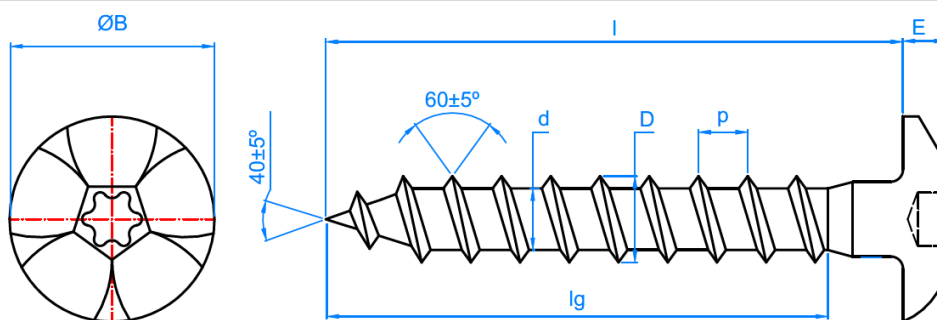

TECHNICAL CHARACTERISTICS			
Essential characteristics	Version	Performance	
		Unit	Ø 7
Characteristic yield moment $M_{y,k}$	Stainless A2	[Nmm]	19396
Characteristic withdrawal parameter (along fibre) $f_{ax,k}$ with $\rho_k = 450 \text{ kg/m}^3$	Stainless A2	[N/mm ²]	13,55
Characteristic withdrawal parameter (across fibre) $f_{ax,k}$ with $\rho_k = 450 \text{ kg/m}^3$	Stainless A2	[N/mm ²]	11,14
Characteristic head pull-through parameter $f_{head,k}$ with $\rho_k = 450 \text{ kg/m}^3$	Stainless A2	[N/mm ²]	23,03
Characteristic traction capacity $f_{tens,k}$	Stainless A2	[kN]	16,20
Characteristic torsion ratio with $\rho_k = 450 \text{ kg/m}^3$	Stainless A2	[-]	2,02
Corrosion protection	Stainless A2	[N/mm ²]	Service class 3 according to EN 1995-1-1

2.7 ESTRINV

Tamperproof star

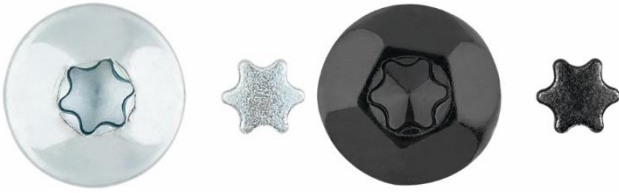

Properties



Zamak 5



Zinc coating



Black zinc coating

Characteristics and advantages

- Zinc coating (ESTRINVZ) and black zinc coating (ESTRINVN).
- Hexalobular Tx 40 recess

- Installation by hitting.
- Application: INVZ, INVN and INVA2 screws.

