



MAHE



MARE



MARI



TALA



MAMH



ABE-RM



VR-SE

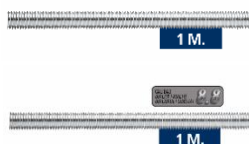

RV – ZN / RV-ZN 8.8

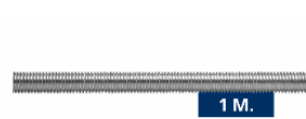

RV – A2





















CHARACTERISTICS

- Versatility in sizes and components
- For suspension mounts with nuts and washers.
- Finished in zinc plated or stainless (according to each element)

EXAMPLES



1.RANGE

ITEM	DENOMINATION	PHOTO	MATERIAL	COATING
1	MAHE		Steel SAE J403 1008	 Zinc plated $\geq 5\mu\text{m}$ ISO 4042 A2J
2	MARE		Steel SAE J403 1008	 Zinc plated $\geq 5\mu\text{m}$ ISO 4042 A2J
3	MARI		Steel A2-70 UNE-EN ISO 3506-1	 Steel A2-70
4	TALA		Brass T-0T58 Pb UNI 5705	 Brass
5	MAMH		Steel Q195	 Zinc-plated $\geq 5\mu\text{m}$ ISO 4042 A2J
6	ABE-RM		Carbon steel	 Zinc-plated $\geq 5\mu\text{m}$ ISO 4042 A2J
7	VR-SE		Steel class 4.8 ISO 898-1	 Zinc plated $\geq 5\mu\text{m}$ ISO 4042 A2J
8	RV-ZN		Steel 4.8 ISO 898-1	 Zinc plated $\geq 5\mu\text{m}$ ISO 4042 A2J
9	RV-ZN 8.8		Steel 8.8 ISO 898-1	 Zinc plated $\geq 5\mu\text{m}$ ISO 4042 A2J
10	RV-A2		Steel A2-70 UNE-EN ISO 3506-1	 Steel A2-70

2. INSTALLATION DATA

2.1 MAHE

Hexagonal coupling nut*



Properties



Steel



Zin Plated coating

Sizes

DRAWING

CODE	MAE0620	MAE0630	MAE0830	MAE1030	MAE1235	MAE1650	MAE2060
Ød: thread	M6	M6	M8	M10	M12	M16	M20
m: total length	20	30	25	30	35	50	60
s: socket	10	10	11	13	17	24	30
Threaded rod	975ZM06	975ZM06	975ZM08	975ZM10	975ZM12	975ZM16	975ZM20

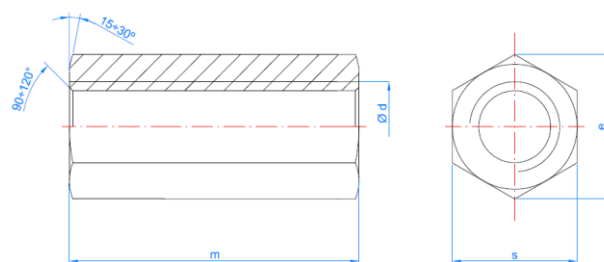

* Resistance equivalent to a screw class 6.8

2.2 MARE

Cylindrical coupling nut*



Properties



Steel



Zin Plated coating

Sizes

CODE		MAR5322	MAR0420	MAR0620	MAR0630	MAR0825	MAR0830	MAR1030	MAR1235	MAR1650
Ød1: thread	[mm]	5/32W	M4	M6	M6	M8	M8	M10	M12	M16
m: total length	[mm]	20	20	20	30	25	30	30	35	50
Ød2: outside diameter	[mm]	7	7	10	10	11	11	13	15	22
Threaded rod		-	975ZM04	975ZM06	975ZM06	975ZM08	975ZM08	975ZM10	975ZM12	975ZM16

DRAWING

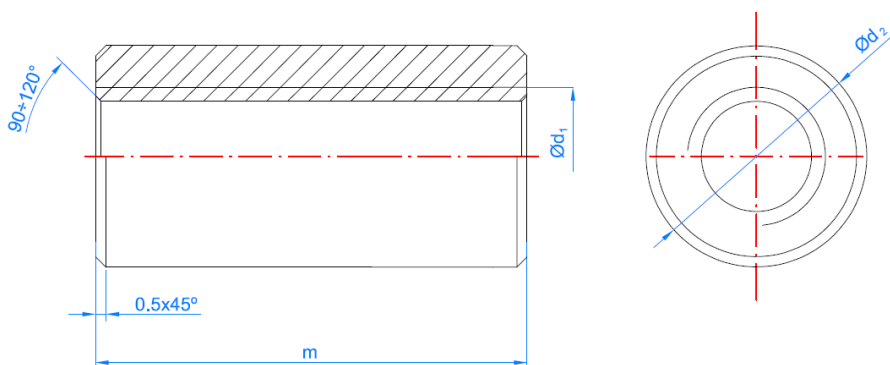

* Resistance equivalent to a screw 6.8

2.3 MARI

Stainless cylindrical coupling nut*



Properties



Stainless steel A2

Sizes

DRAWING

CODE		MARI0830	MARI1030
d∅: thread	[mm]	M8	M10
m: total length	[mm]	30	30
∅d2: outside diameter	[mm]	11	13
Threaded rod		975A2M10	975A2M10

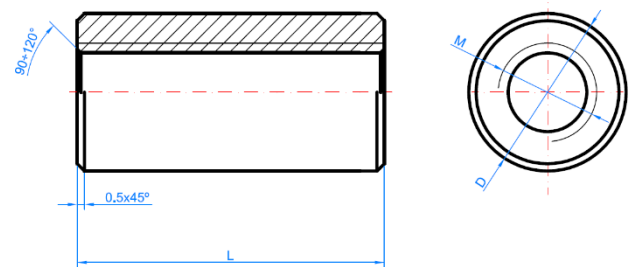

* Resistance equivalent to a screw 6.8

2.4 TALA

Brass expansion anchor



Properties



Brass

Sizes

CODE	Size	Length	d_0	h_1	$h_{ef} = h_{nom}$	h_{min}	Maximum Recommended Load
	[mm]	[mm]	[mm]	[mm]	[mm]	[mm]	[kg]
TALA532	W5/32	16	5	20	16	25	60
TALAM04	M4	16	5	20	16	25	60
TALAM05	M5	18	6	22	18	30	70
TALAM06	M6	23	8	28	23	35	100
TALAM08	M8	28	10	33	28	40	150
TALAM10	M10	34	12	40	34	45	210
TALAM12	M12	38	15	45	38	50	320

Drawing

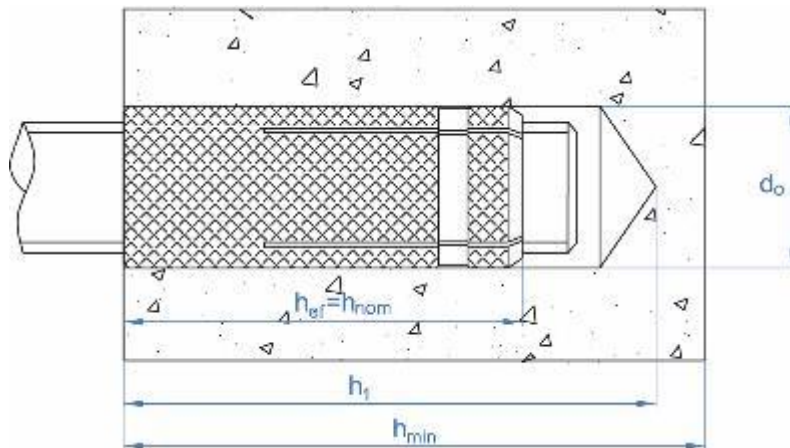

2.5 MAMH

Spacer nut M/F



Properties



Steel



Zin Plated coating

Sizes

CODE	A	B	L	SW
MAMH0610	8	8	10	10
MAMH0620	10	12	20	10
MAMH0630	10	18	30	10
MAMH0640	10	18	40	10
MAMH0650	10	18	50	10

DRAWING

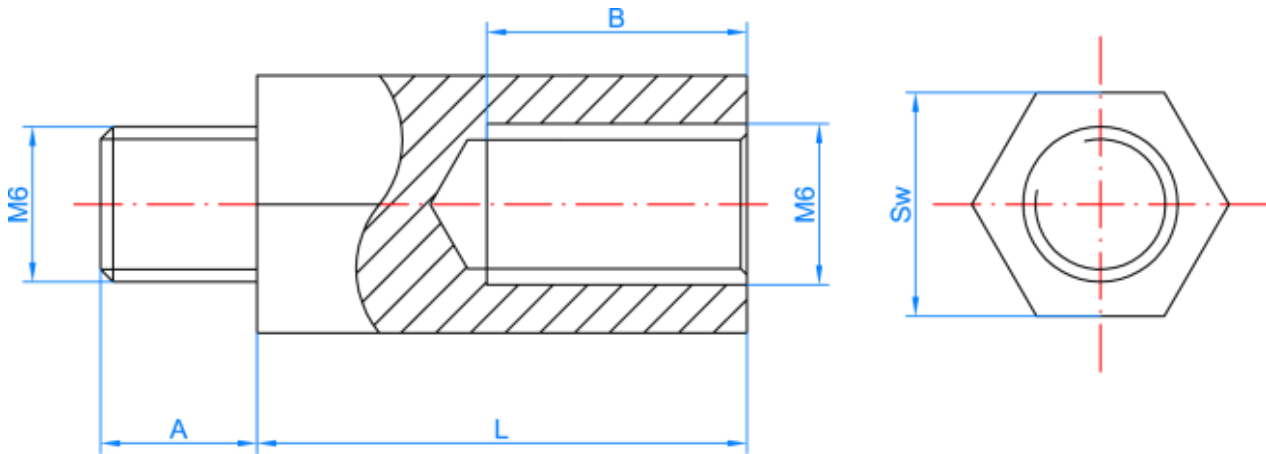

2.6 ABE-RM

Self-drilling screw for clamps



Properties



Steel



Zinc plated coating

Sizes

CODE	M	L	L2	L1	s	Thickness to be drilled
ABERM06006	M6	30,0	19,5	5	10	2,5 – 6
ABERM08010*	M8	35,5	19,5	10	13	2,5 – 6
ABERM08015**	M8	40,5	19,5	15	13	2,5 – 6

DRAWING

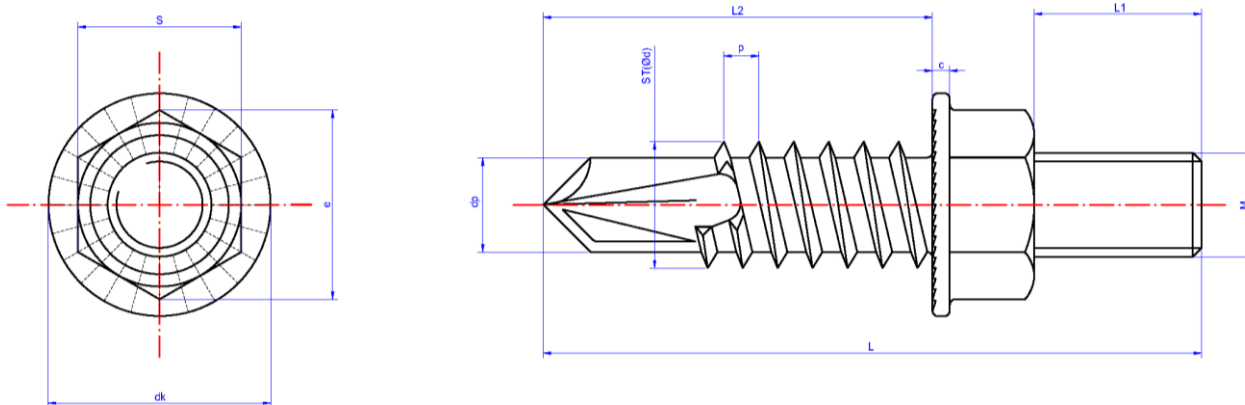

* Recommended use on clamps with M8 thread.

** Recommended use on clamps with M8/M10 thread due to their length L1= 15mm.

2.7 VR-SE

Small threaded bolt



Properties



Steel



Zin Plated coating

Sizes

DRAWING

CODE		VRSE06020	VRSE06030	VRSE08020	VRSE08030	VRSE10030	VRSE12030
M: \varnothing thread	[mm]	M6	M6	M8	M8	M10	M12
L: Total length	[mm]	20	30	20	30	30	35

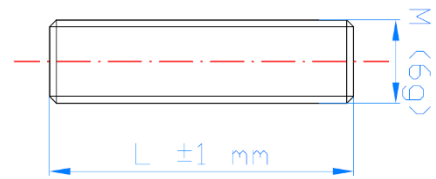

2.8 RV-ZN

Zinc plated threaded rod bar steel 4.8



1 M.

Properties



Steel



Zinc plated

Sizes

CODE	ØM	Effective section A _s [mm ²]	Characteristic tensile strength N _{k,s} [N]	Drawing	
975ZM04	M4	8.78	3.690		
975ZM05	M5	14.2	5.960		
975ZM06	M6	20.1	8.440		
975ZM08	M8	36.6	15.400		
975ZM10	M10	58	24.400		
975ZM12	M12	84.3	35.400		
975ZM14	M14	115	48.300		
975ZM16	M16	157	65.900		
975ZM18	M18	192	80.600		
975ZM20	M20	245	103.000		
975ZM22	M22	303	127.000		
975ZM24	M24	353	148.000		
975ZM27	M27	459	193.000		
975ZM30	M30	561	236.000		
975ZM33	M33	694	292.000		
975ZM36	M36	817	343.000		
975ZM2M06	M6	20.1	8.440		2 meters

2.9 RV-ZN 8.8

Zinc plated threaded rod bar steel 8.8

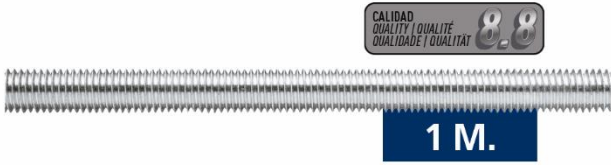

Properties



Steel



Zinc plated

Sizes

CODE	ØM	Effective section A _s [mm ²]	Characteristic tensile strength N _{k,s} [N]	Drawing
9758ZM05	M5	14.2	11.350	
9758ZM06	M6	20.1	16.100	
9758ZM08	M8	36.6	29.200	
9758ZM10	M10	58	46.400	
9758ZM12	M12	84.3	67.400	
9758ZM14	M14	115	92.000	
9758ZM16	M16	157	125.000	
9758ZM18	M18	192	159.000	
9758ZM20	M20	245	203.000	
9758ZM22	M22	303	252.000	
9758ZM24	M24	353	293.000	
9758ZM27	M27	459	381.000	
9758ZM30	M30	561	466.000	
9758ZM33	M33	694	576.000	
9758ZM36	M36	817	678.000	

2.10 RV-A2

Stainless steel threaded rod bar

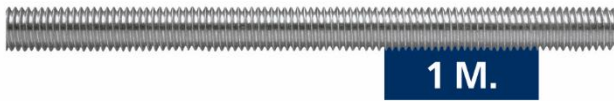

Properties



Stainless steel A2

Sizes

CODE	ØM	Effective section A _s [mm ²]	Characteristic tensile strength N _{k,s} [N]	Drawing
975A2M04	M4	8.78	6.146	
975A2M05	M5	14.2	9.940	
975A2M06	M6	20.1	14.070	
975A2M08	M8	36.6	25.620	
975A2M10	M10	58	40.600	
975A2M12	M12	84.3	59.010	
975A2M14	M14	115	80.500	
975A2M16	M16	157	109.900	
975A2M18	M18	192	134.400	
975A2M20	M20	245	171.500	
975A2M22	M22	303	212.100	
975A2M24	M24	353	247.100	
975A2M27	M27	459	321.300	
975A2M30	M30	561	392.700	
975A2M33	M33	694	485.800	
975A2M36	M36	817	571.900	