

TECHNICAL DATASHEET:

Solar range / Profiles, joints, channels and connectors for supporting structure

PSE-C

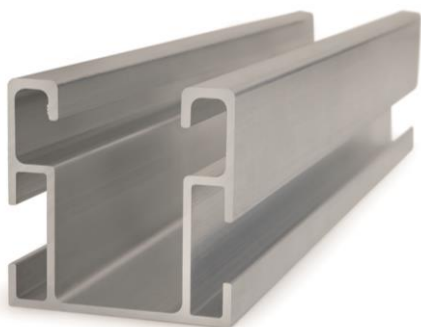

PRODUCT DESCRIPTION

- Aluminium profile for assembled fixing

CHARACTERISTICS

- Profile for installation of solar panels on roofs.
- Extruded 6063-T6 aluminium alloy profile.
- For outside use.
- Designed for coplanar assembly systems.
- Assembled, detachable and reusable fixing.
- Profile height – 40 mm, with high bending resistance.
- General thickness – 1.5 mm.
- Central groove compatible with INDEXTRUT accessories.
- Available in anodized.

APPLICATIONS/MOUNTING ACCESSORIES



KFRSC3050 / KFRSCN3050

These are used in **coplanar aluminium installation systems** as structural elements onto which solar panels can be mounted and supported as continuous profiles.

In order to attach solar panels to the profile, one of the following assembly accessories should be used:

1. **KFRSC3050 / KFRSCN3050** “quick pre-assembled clamp”.
2. Reference numbers:
 - One **PGSA26 / PGSN26** “simple clamp”.
 - One **TURXA208** “INDEXTRUT quick nut”.
 - One **6921108070** DIN-6921 M8x70 all-thread bolt.

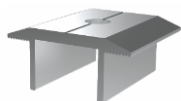

PGSA26 / PGSN26



TURXA208



6921108070



PSECUN200



ABEI5519

When lengthwise connections are made between profiles, the **PSECUN200** “connector for aluminium profile for assembled fixing” is used, with the fixing made using stainless steel A2-70 **ABEI5519** “DIN-7504-K self-drilling screws”. These screws are easily positioned thanks to the grooves in the sides of the profiles.

TECHNICAL DATASHEET:

Solar range / Profiles, joints, channels and connectors for supporting structure

FIXING SYSTEM/ASSEMBLY ACCESSORIES





Mounting with direct fixing/Application example 1

FIXING SYSTEM			ACCESSORIES	
	TAC-N / TAC-B Atlantis/Bimetal thin sheet screw	DIN-7504-K RE NI+ARVUL Atlantis C4-M reduced point self-drilling screw		CS-B Butylene adhesive sealing tape

Mounting on adjustable fixing systems/Application example 2

FIXING SYSTEM				ACCESSORIES	
	PMO-L Plate for double threaded screw	GS-TC / GS-TU Adjustable roof hook for Curved/universal tiles	STR Adjustable support for trapezoidal roof		KFS-FI Cross connector for fixing

Mounting on inclined structures/Application example 3

FIXING SYSTEM				ACCESSORIES	
	TPA-R Pre-assembled an adjustable aluminium triangle	TPA-A Pre-assembled aluminium open triangle	TPA-C Pre-assembled aluminium closed triangle		KFS-FC Cross connector for lateral fixing

BASE MATERIAL/FIXING

See technical datasheet:

- Coplanar installation system with PSE-C aluminium profile. Assembled fixing (SC-PSEC).
- Triangular installation system with PSE-C aluminium profile. Assembled fixing (ST-PSC).
- Triangular installation system with aluminium open triangle (ST-PTA)
- Triangular installation system with aluminium closed triangle (ST-PTC)

APPLICATION EXAMPLES

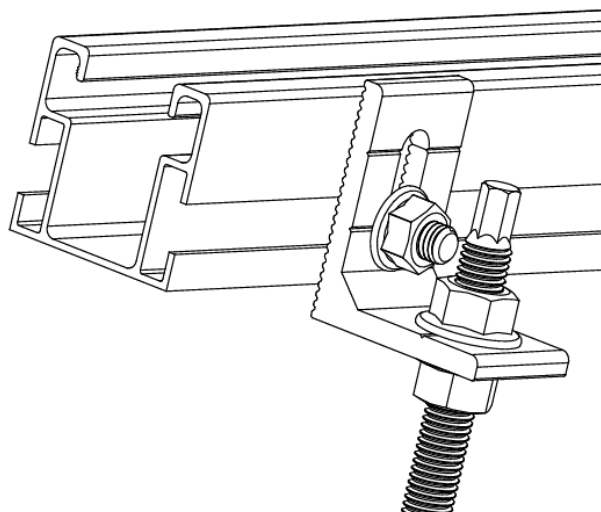

Application example 1: mounting on double threaded screw

TECHNICAL DATASHEET:

Solar range / Profiles, joints, channels and connectors for supporting structure

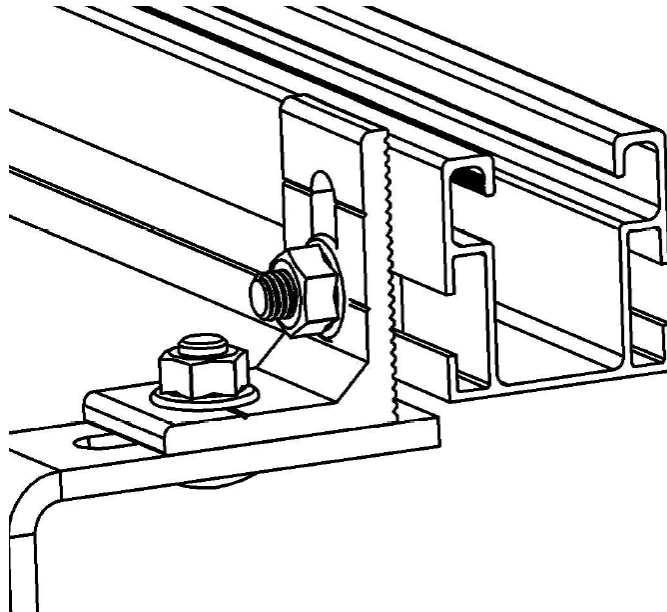

Application example 2: mounting on curved/universal tile roof hooks

1. RANGE

ITEM	CODE	PICTURE	DESCRIPTION	LENGTH	MATERIAL	AVAILABLE FINISH
1	PSEC410125		Aluminium profile for assembled fixing	125 mm	 Aluminium 6063-T6	 Natural anodized 15 microns (AA15)
	PSEC410200			200 mm		
	PSEC411250			1250 mm		
	PSEC411875			1875 mm		
	PSEC412500			2500 mm		
	PSEC413625			3625 mm		
	PSEC414400			4400 mm		
	PSEC414800			4800 mm		

Mechanical properties of the material

	Yield strength $F_{y0.2}$ (N/mm ²)	Ultimate load F_u (N/mm ²)	Elastic modulus E (N/mm ²)	Transverse elastic modulus G (N/mm ²)	Linear expansion coefficient α_L ($\mu\text{m}/\text{C}^\circ$)	Specific weight ρ (kg/m ³)
Aluminium EN AW-6063-T6	170	215	69.500	26.100	23,5	2.700

Mechanical properties of the profile.

	Area S (cm ²)	Moment of inertia I_x (cm ⁴)	Moment of inertia I_y (cm ⁴)	Section modulus W_x (cm ³)	Section modulus W_y (cm ³)	Linear weight W (kg/m)
 PSE-C	2,92	6,14	7,02	2,99	3,43	0,79

2.INSTALLATION DATA

2.1 PSE-C

Aluminium profile for coplanar assembled fixing

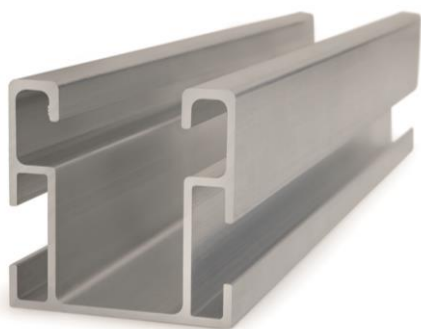

Material	Available finish	Assembly accessories		
		 KFRSC3050 / KFRSCN3050 Quick pre-assembled clamp	 PSECUN200 Connector for PSE-C profile	 ABE15519 A2 DIN-7504-K bolt
		 PGSA26 / PGSN26 Simple clamp	 TURXA208 INDEXTRUT quick nut	 6921108070 A2-70 DIN-6921 stainless steel bolt
Aluminium 6063-T6	Natural anodized 15 µm (AA15)			

Fixing systems			Assembly accessories
 TPA-R Pre-assembled and adjustable aluminium triangle	 TPA-A Pre-assembled aluminium open triangle	 TPA-C Pre-assembled aluminium closed triangle	 KFS-FC Cross connector for lateral fixing
 TAC-N / TAC-B Atlantis/Bimetal thin sheet screw		 DIN-7504-K RE NI + ARVUL Atlantis C4-M reduced point self-drilling screw	 CS-B Cinta estanqueidad de butileno
 PMO-L Plate for double threaded screw	 GS-TC / GS-TU Adjustable roof hook for curved/universal tiles	 STR Adjustable support for trapezoidal roof	 KFS-FI Cross connector for bottom fixing

BASE MATERIAL/FIXING

See technical data sheets:

- **SC-PSEC:** Coplanar installation system on aluminium profile for assembled fixing
- **ST-PSC:** Triangular installation system on aluminium profile for assembled fixing.
- **ST-PTA:** Triangular installation system with aluminium open triangle
- **ST-PTC:** Triangular installation system with aluminium closed triangle.

Installation data

Code	A (mm)	B (mm)	C (mm)	D (mm)	E1 (mm)	E2 (mm)	G (mm)	H (mm)	L (mm)
PSEC410125	41	41	22	7	1,8	1,5	23	41	125
PSEC410200	41	41	22	7	1,8	1,5	23	41	200
PSEC411250	41	41	22	7	1,8	1,5	23	41	1250
PSEC411875	41	41	22	7	1,8	1,5	23	41	1875
PSEC412500	41	41	22	7	1,8	1,5	23	41	2500
PSEC413625	41	41	22	7	1,8	1,5	23	41	3625
PSEC414400	41	41	22	7	1,8	1,5	23	41	4400
PSEC414800	41	41	22	7	1,8	1,5	23	41	4800

Drawing

