

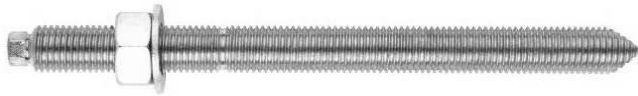

CAQU

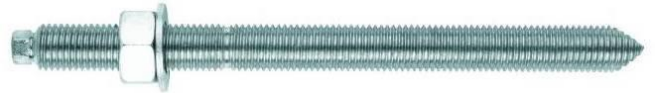

EQA2



EQAC

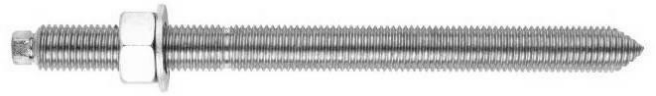

EQA4

CHARACTERISTICS

- Chemical anchor, consisting of a chemical capsule which reacts to stud installation.
- Male thread.
- Non-expansive anchor: no expansion tension induced on base material.
- Suitable for loads subjected to vibrations.
- Reduced critical edge distance and spacing between anchors.
- Easy installation.
- Available in zinc-plated, AISI 304 (A2) stainless steel and AISI 316 (A4) stainless steel.
- Once installed, fixture may be disassembled without affecting anchor.
- Does not produce dangerous or toxic residues.
- Continuous working temperature range of -40° to +50 °C (for short periods: +80 °C).
- Suitable for wet hole installations.
- Avoid contact with drinking water and food.
- Certified by the European Organization for Technical Approvals (EOTA) in Option 8 for non-cracked concrete, ETA 08/0350.



APPLICATIONS

- For use with medium-heavy loads in non-cracked concrete.
- Not suitable for ceiling installations.
- For securing machinery and elements subjected to vibrations.

See Web profile:



BASE MATERIALS



HORMIGÓN



LADRILLO
MACIZO



PIEDRA

APPLICATION EXAMPLES



1. MATERIALS

ITEM	COMPONENT	ZINC-PLATED	A2/A4 STAINLESS
1	Capsule	Glass blister with base component, cold curing resin and hardener	
2	Threaded stud	Steel class 5.8 ISO 898-1, zinc-plated $\geq 5 \mu\text{m}$	A2-70 (AISI 304) A4-70 (AISI 316)
3	DIN 125 Washer	Zinc-plated $\geq 5 \mu\text{m}$	A2-70 (AISI 304) A4-70 (AISI 316)
4	DIN 934 Nut	Resistance class 5 according to DIN 934, zinc-plated $\geq 5 \mu\text{m}$	A2-70 (AISI 304) A4-70 (AISI 316)

Capsule storage conditions: in original packaging, away from heat sources and direct sunlight.

Shelf life: 18 months from manufacturing date. Indicated on packaging. The following graph shows the ratio between storage temperature and product life:

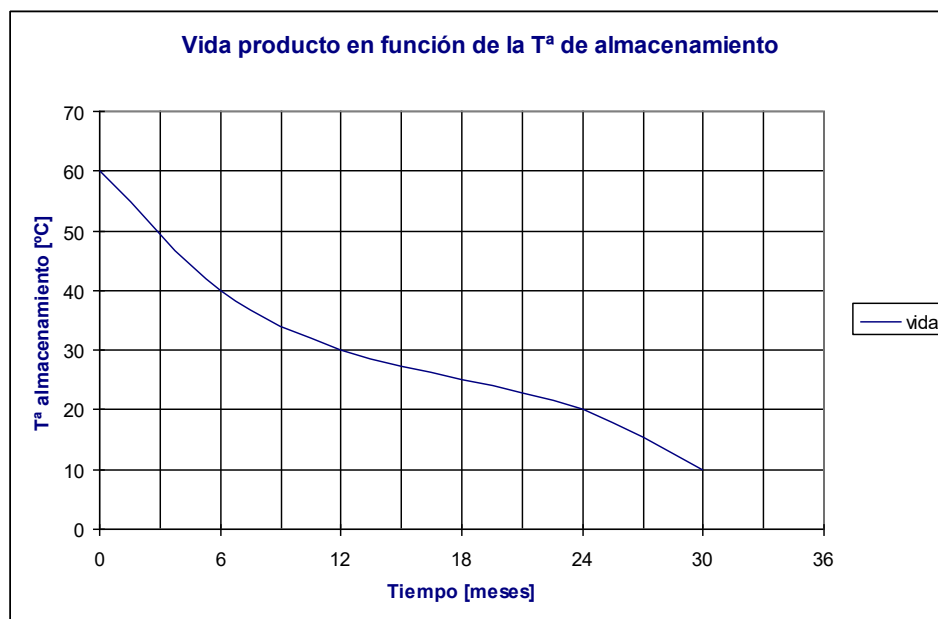

2. DIMENSIONS

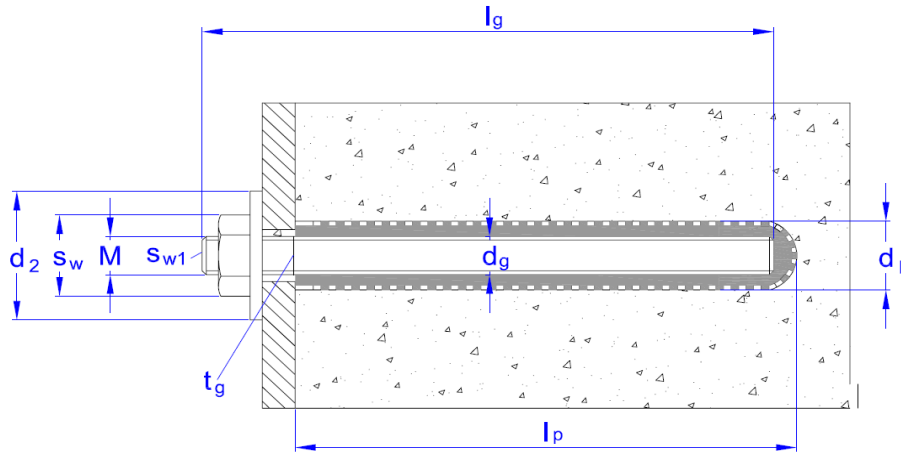

MEASUREMENT		M8	M10	M12	M16	M20	M24	M30*
Code	Chemical capsule	CAQU008	CAQU010	CAQU012	CAQU016	CAQU020	CAQU024	CAQU030
	Bichromated stud	EQAC08110	EQAC10130	EQAC12160	EQAC16190	EQAC20260	EQAC24300	EQAC30330
	Stainless stud	A2	EQA208110	EQA210130	EQA212160	EQA216190	EQA220260	EQA224300
A4		EQA408110	EQA410130	EQA412160	EQA416190	EQA420260	EQA424300	EQA430330
d _p : capsule diameter	[mm]	9	11	13	17	22	24	33
l _p : capsule length	[mm]	80	80	95	95	170	210	265
d ₂ : washer diameter	[mm]	17	21	24	30	37	44	56
s ₂ : washer thickness	[mm]	1.6	2	2.5	3	3	4	4
s _w : spanner	[mm]	13	17	19	24	30	36	46
d _G : stud diameter	[mm]	8	10	12	16	20	24	30
l _G : stud length	[mm]	110	130	160	190	260	300	330
t _G : threaded stud stamp	[mm]	80	90	110	125	170	210	--
s _{w1} : stud spanner	[mm]	5	8	8	12	13	13	--
Product volume/capsule	[ml]	4,0	5,5	9,0	15,8	53,0	76,0	191,0

*not included in ETA approval

3. INSTALLATION DATA

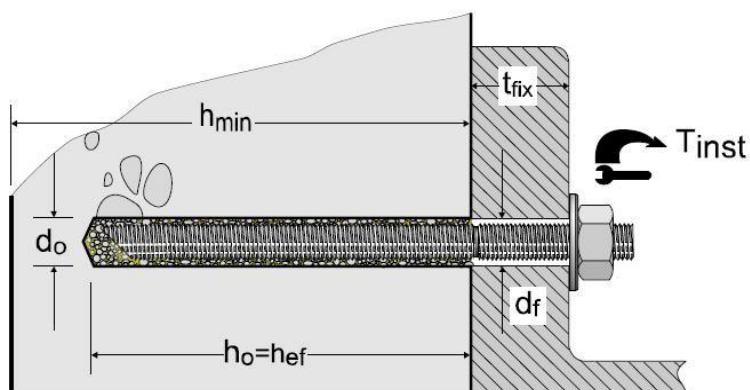

MEASUREMENT		M8	M10	M12	M16	M20	M24	M30*
Code	Chemical capsule	CAQU008	CAQU010	CAQU012	CAQU016	CAQU020	CAQU024	CAQU030
	Bichromated stud	EQAC08110	EQAC10130	EQAC12160	EQAC16190	EQAC20260	EQAC24300	EQAC30330
	Stainless stud	A2	EQA208110	EQA210130	EQA212160	EQA216190	EQA220260	EQA224300
A4		EQA408110	EQA410130	EQA412160	EQA416190	EQA420260	EQA424300	EQA430330
d ₀ : drill bit diameter	[mm]	10	12	14	18	25	28	35
h ₁ : drillhole depth	[mm]							
h _{nom} : installation depth	[mm]	80	90	110	125	170	210	280
h _{ef} : effective depth	[mm]							
h _{min} : min. thickness base material	[mm]	110	120	140	160	220	260	360
t _{fix} : max. fixture thickness	[mm]	17	25	32	44	66	62	22
Metal cleaning brush diameter	[mm]	14		20		29		
Metal cleaning brush codes		MORCEPKIT (3 brush kit of ø14, ø20 and ø29)						
d _f : fixture diameter ≤	[mm]	9	12	14	18	22	26	33
T _{ins} : torque ≤	[Nm]	10	20	40	80	120	180	400
S _{cr} : critical spacing	[mm]	240	180	220	250	340	420	560
C _{cr} : critical Edge distance	[mm]	120	90	110	125	170	210	280

4. INSTALLATION PROCEDURE

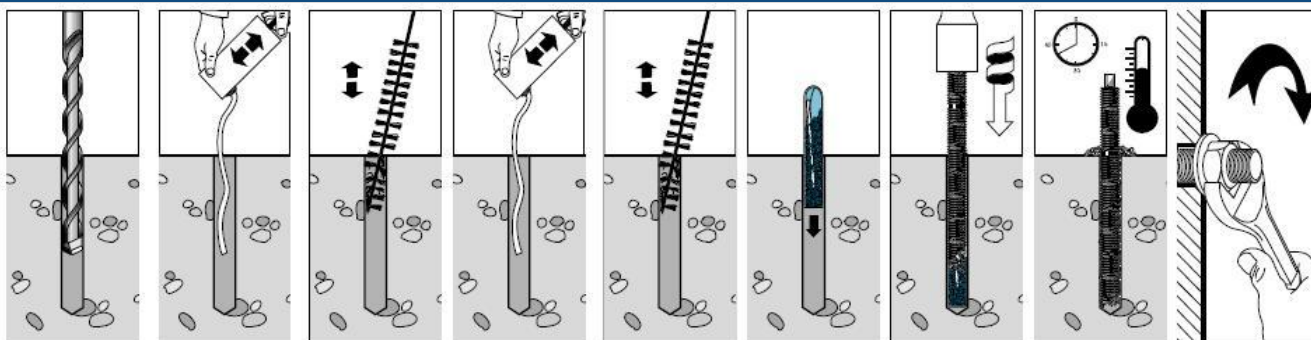

- Check concrete is well compacted and without significant pores.
- Admissible base material temperatures during installation: -5 / + 50 °C
- Anchors must be installed ensuring the minimum specified depth. Critical spacing and critical edge distance for concrete must be respected, no minus tolerances.
- Drill to minimum depth and diameter specified, maintaining perpendicularity with base material surface. If a deeper drill hole is required for structural reasons, a longer stud with the same measurements must be employed.

- Care must be taken so as not to damage reinforcements near the drillhole. In the event of aborting drilling (for example due to finding reinforcement), it is recommended a new hole be drilled at a minimum distance of twice the depth of the aborted drillhole, or alternatively closer, as long as the initial drillhole is filled with high-resistance mortar. In any case, if the initial drillhole is not filled with mortar, shear or oblique force will not be permitted in the same direction at a distance less than the installation depth h_{nom} .
- Clear hole of dust and fragments from drilling. Use a manual pump and a circular brush for the specified diameter. Repeat this operation twice. Take extra precaution with this point for this type of anchor.
- Check resin moves around easily inside the capsule at a lukewarm temperature.
- For temperatures below 0 °C, ensure no water enters the drillhole as it may produce local cracking of the concrete due to ice pressure.
- Insert capsule into the drillhole in either direction.
- Insert threaded stud into the drillhole, breaking the capsule, whilst turning it with a drill set at hammer position at 250 ÷ 750 rpm until it reaches the bottom (marked by the threaded stud), maintain perpendicularity to the base material; use a socket wrench attached to the drill. As soon as the stud reaches the bottom, stop drill so as to prevent resin escaping.
- Remove drill, taking care not to extract the threaded stud from its housing.
- Observe the capsule contents overflow from the top of the drillhole (this overflow occurs when indicated installation depth and diameter values are followed). If not, quickly remove the threaded stud and use a second chemical capsule, repeating the process.
- Respect curing time specified in the table without moving the threaded stud or applying loads. In ceiling installations, ensure mortar does not seep from drillhole.

Concrete temperature	Minimum concrete curing time	
	Dry hole	Wet hole
≥ -5 °C	5 hrs.	10 hrs.
≥ 0 °C	5 hrs.	10 hrs.
≥ +5 °C	1 hr.	2 hrs.
≥ +10 °C	1 hr.	2 hrs.
≥ +20 °C	20 min.	40 min.
≥ +30 °C	10 min.	20 min.
≥ +35 °C	10 min.	20 min.

- Once the curing time has elapsed, position the element to be fixed without any kind of intermediate layer (sealants, etc.), and apply indicated torque using a torque wrench.
- It must also be checked that the threaded stud does not bend, therefore the following requisites must be met:
 - The element to be fixed is metallic and is positioned flat against the concrete, with no intermediate layer.
 - The element to be fixed is in complete contact with the washer.
 - The mortar, once threaded stud is in position, overflows from the drillhole.
 - The drillhole diameter in the element to be fixed d_f is no greater than that indicated in the installation details section.
- If these requisites cannot be met, a reinforced washer must be installed; although shear forces on a group of anchors will only be transmitted by those anchors with the correct diameter in the element to be fixed.

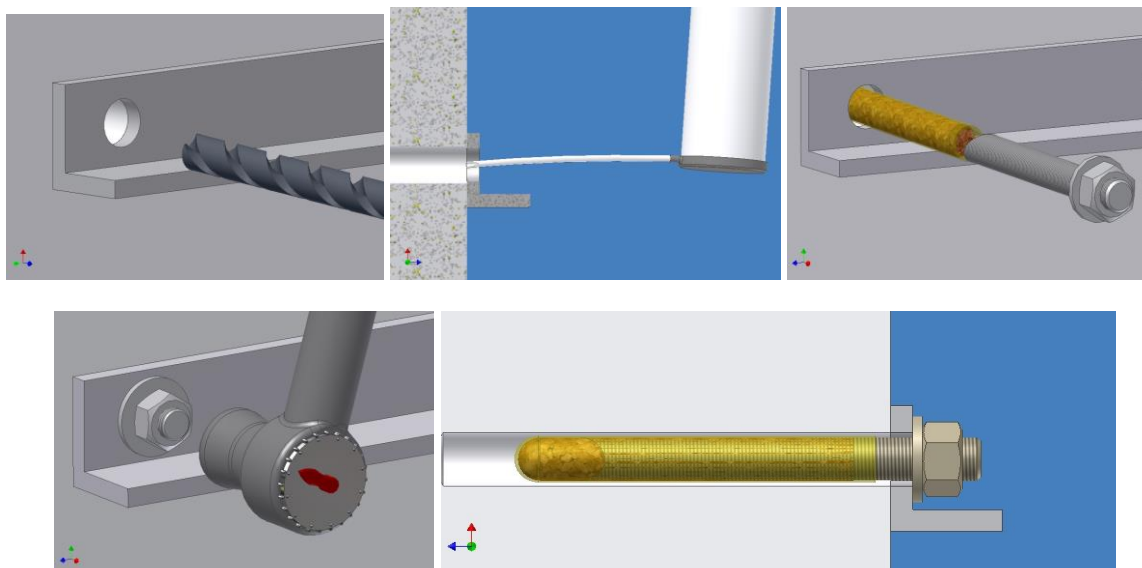

5. CHARACTERISTICS RESISTANCES

MEASUREMENT		M8	M10	M12	M16	M20	M24	M30
Zinc-plated	Code	CAQU008 EQAC08110	CAQU010 EQAC10130	CAQU012 EQAC12160	CAQU016 EQAC16190	CAQU020 EQAC20260	CAQU024 EQAC24300	CAQU030 EQAC30330
	N _{R,k} : Tension	[KN] 20.0	30.0	40.0	50.0	75.0	90.0	135.0
	V _{R,k} : Shear	[KN] <u>9.0</u>	<u>14.0</u>	<u>21.0</u>	<u>39.0</u>	<u>61.0</u>	<u>88.0</u>	<u>146.0</u>
A2 Stainless	Code	CAQU008 EQA208110	CAQU010 EQA210130	CAQU012 EQA212160	CAQU016 EQA216190	CAQU020 EQA220260	CAQU024 EQA224300	CAQU030 EQA230330
	N _{R,k} : Tension	[KN] 20.0	30.0	40.0	50.0	75.0	90.0	135.0
	V _{R,k} : Shear	[KN] <u>13.0</u>	<u>20.0</u>	<u>29.0</u>	<u>55.0</u>	<u>86.0</u>	<u>124.0</u>	<u>196.0</u>
A4 Stainless	Code	CAQU008 EQA408110	CAQU010 EQA410130	CAQU012 EQA412160	CAQU016 EQA416190	CAQU020 EQA420260	CAQU024 EQA424300	CAQU030 EQA430330
	N _{R,k} : Tension	[KN] 20.0	30.0	40.0	50.0	75.0	90.0	135.0
	V _{R,k} : Shear	[KN] <u>13.0</u>	<u>20.0</u>	<u>29.0</u>	<u>55.0</u>	<u>86.0</u>	<u>124.0</u>	<u>196.0</u>

1 KN ≈ 100 Kg

* The characteristic resistance of an anchor is that of a 95% probability of being surpassed in a breakage test. It depends on the average breakage resistance values, on the number of tests performed and on result dispersion.

** C20/25 Concrete according to ENV206: characteristic resistance for a sample of ≥ 28 days old:

- Cylindrical sample ø 150 mm. x 300 height ≥ 200 N/mm²
- Cubic sample 150 mm. side ≥ 250 N/mm²

Underlined italic figures indicate steel failure

Characteristic resistance values for tension and shear must be considered separately

6. RECOMMENDED SAFETY COEFFICIENTES

SAFETY COEFFICIENTS		RESISTANCE DEDUCTION COEFFICIENT		LOAD INCREMENT COEFFICIENTS
		CONCRETE FAILURE	<u>STEEL FAILURE</u>	
Bichromated steel	Tension	1.80	--	1.4
	Shear	--	<u>1.25</u>	
A2 Stainless steel	Tension	1.80	--	
	Shear	--	<u>1.56</u>	
A4 Stainless steel	Tension	1.80	--	
	Shear	--	<u>1.56</u>	

7. CALCULATION EXAMPLE

Fixing a 2.000 kg tension load

2.000 kg ≈ 20 KN

Load increment coefficient: 1.4

Use of two M10 chemical capsules with zinc-plated threaded stud 30.0 KN

Concrete failure

Resistance deduction coefficient for concrete failure: 1.8

Checking: factored load must be less than reduced resistance

$$20 \text{ KN} \times 1.4 \leq 2 \times 30.0 \text{ KN} / 1.8$$

Critical spacing between anchors must be a minimum of 180 mm, and keep a minimum critical edge distance (from any edge) of 90 mm.