



ARVUL



ARPAR



ARVUL A2



ARPAR A2



ARINOM

CARACTÉRISTIQUES

- Rondelle métallique avec joint EPDM.
- Adéquate pour une fermeture étanche entre des plaques des façades et celles des toitures.
- Résistante à l'action des rayons ultraviolets et à l'effet de l'ozone.
- Fabriquées en acier galvanisé et en acier inoxydable.
- Différents diamètres.

1. GAMME

ITEM	CODE	PHOTO	MATÉRIEL	RECOUVREMENT
1	ARVUL		EN10142-DX51D+Z140-MB-O EPDM selon ASTM D2240-15	
2	ARVUL A2		Acier Inoxydable A2 (AISI 304) EPDM selon ASTM D2240-15	
3	ARINOM30		Acier Inoxydable A2 (AISI 304) EPDM selon ASTM D2240-15	
4	ARPAR		Acier au carbone Z120, zingué EPDM selon ASTM D2240-15	
5	ARPAR A2		Acier Inoxydable A2 (AISI 304) EPDM selon ASTM D2240-15	

## 2. DONNÉES D'INSTALLATION

### 2.1 ARVUL



CODE	Valable pour les vis :	ØA	ØB	ØC	E1	E2
ARANE14	Ø4,2 – Ø4,8	14,00	6,75	2,5	0,80	2,20
ARANE16	Ø4,2 – Ø6,3	16,00	6,75	2,75	0,80	2,20
ARANE18	Ø4,2 – Ø6,3	18,00	6,75	3,25	0,80	2,20
ARANE25	Ø4,8 – Ø6,3	25,00	6,75	3,5	0,80	2,20

#### PLAN

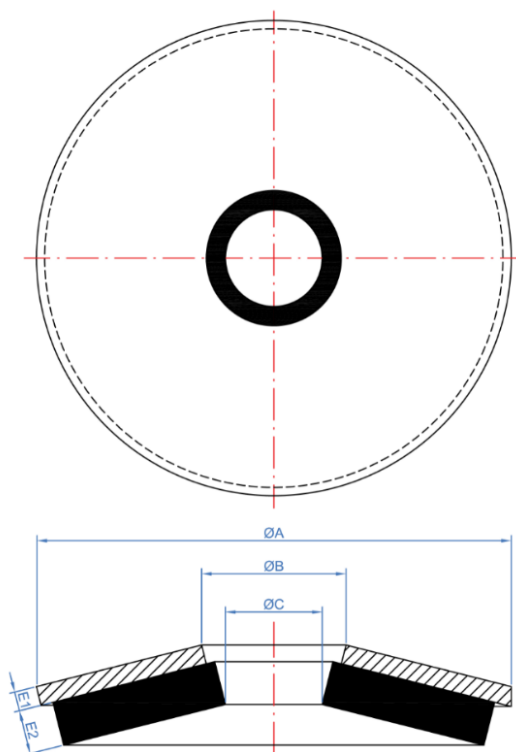

## 2.2 ARVUL A2



CODE	Valable pour les vis :	$\varnothing A$	$\varnothing B$	$\varnothing C$	E1	E2
ARINO14	$\varnothing 4,2 - \varnothing 4,8$	14,00	6,75	2,5	0,80	2,20
ARINO16	$\varnothing 4,2 - \varnothing 6,3$	16,00	6,75	2,75	0,80	2,20
ARINO18	$\varnothing 4,2 - \varnothing 6,3$	18,00	6,75	3,25	0,80	2,20
ARINO25	$\varnothing 4,8 - \varnothing 6,3$	25,00	6,75	3,5	0,80	2,20

### PLAN

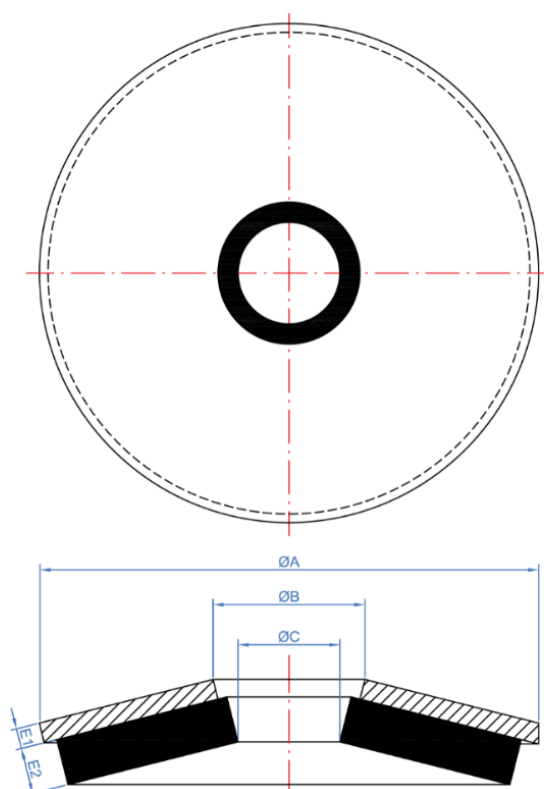

## 2.3 ARINOM



CODE	Valable pour les vis :	ØA	ØB	ØC	E1	E2
ARINOM30	M6	30	9,40	6,30	8,00	0,80

### PLAN

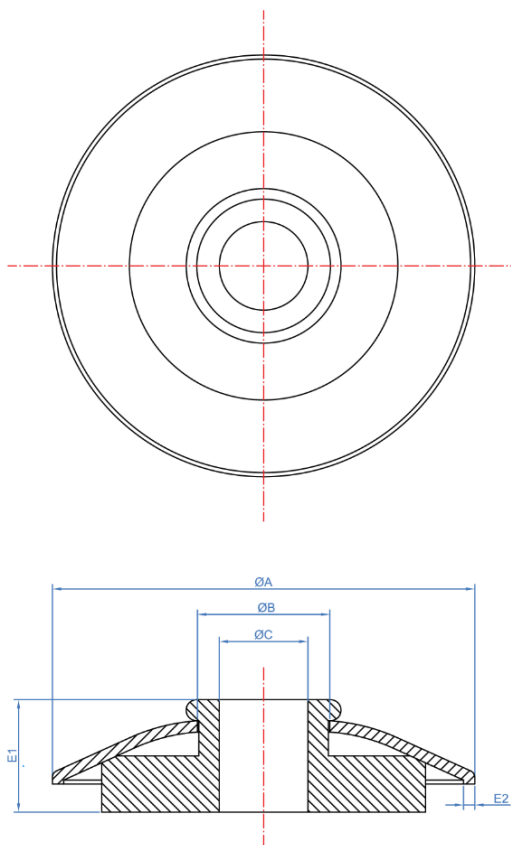

## 2.4 ARPAR



CODE	A	B	C	D	E	F1	G
ARPAR25	22,00	1,00	10,30	3,00	25,00	7,00	13,00

### PLAN

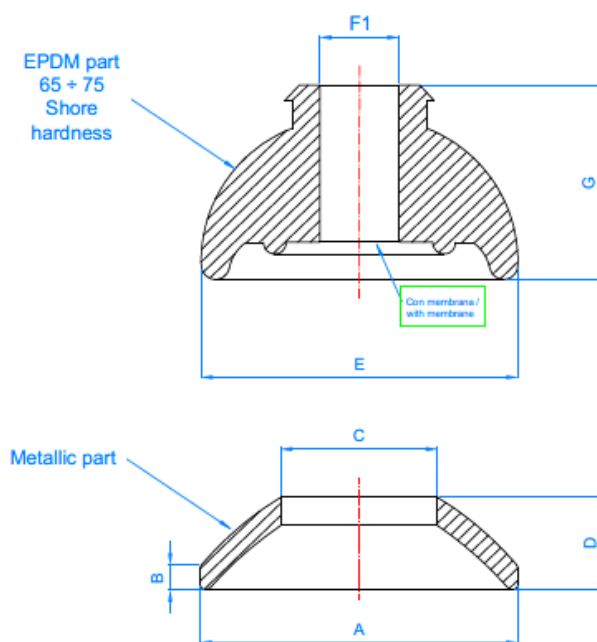

## 2.5 ARPAR A2



CODE	A	B	C	D	E	F1	G
ARPARA225	22,00	1,00	10,30	3,00	25,00	7,00	13,00

### PLAN

