



OME



CAB



EMP



PCU



HO-CU



HO-CR



MA-BM



ADU



SUS

CARACTERISTICAS

- Accesorios para instalaciones de placa de yeso laminado con marcado CE.
- Fácil montaje.
- Variedad de soluciones para diferentes aplicaciones.
- Agujeros con rocas métricas para mejorar la instalación con varillas métricas.
- Válidos para perfil 47 y 60.
- Fabricados en acero galvanizado.

EJEMPOS DE APLICACIÓN



1. GAMA

ITEM	CÓDIGO	DESCRIPCIÓN	FOTO	MATERIAL	RECUBRIMIENTO
1	OME	Anclaje universal		Acero al carbono	
2	HO-CU	Horquilla de cuelgue		Acero al carbono	
3	HO-CR	Horquilla de cuelgue		Acero al carbono	
4	EMP	Empalme de perfiles		Acero al carbono	
5	CAB	Caballete para cruce de perfiles		Acero al carbono	
6	MA-BM	Media abrazadera M6 cincada		Acero	
7	PCU	Acero EN10142-DX51D+Z140-M-B-O		Cincado $\geq 5\mu\text{m}$ ISO 4042 A2J	
8	ADU	Anclaje directo "U" para fijación de perfiles		Acero al carbono	
9	SUS	Accesorio para suspensión		Acero al carbono	

2. DATOS DE INSTALACIÓN

2.1 OME

Anclaje universal

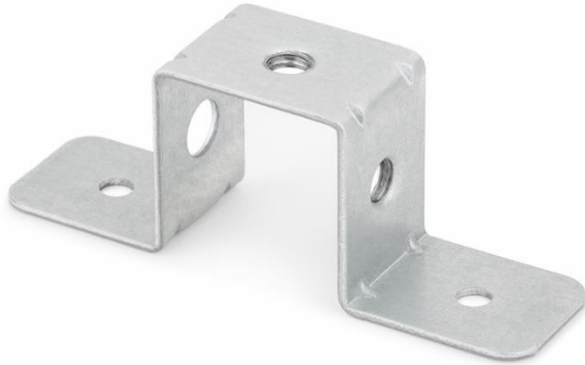

MATERIALES Y GEOMETRÍA



Galvanizado



Instalación de perfiles

CARACTERÍSTICAS

- Omega para fijación a techo.
- Para descolgar varilla roscada.
- Con 2 roscas M6.
- Agujero lateral pasante.
- Cumple con la EN 13964:2006

CÓDIGO

OMEM06

A

B

C

D

76

27

27

20

PLANO

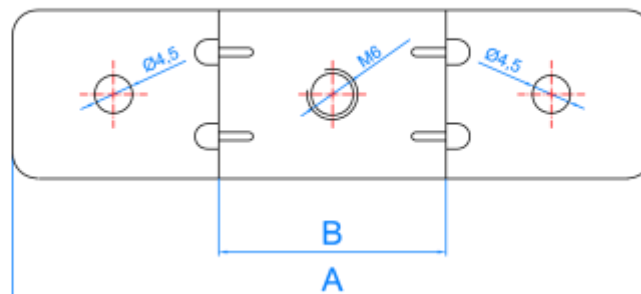
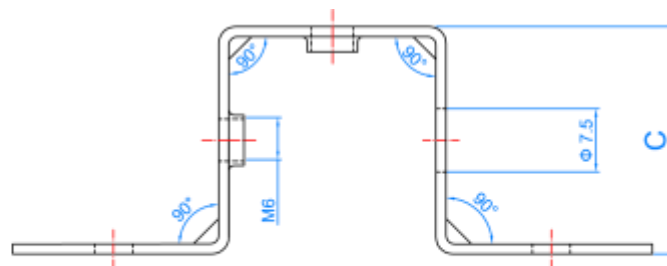
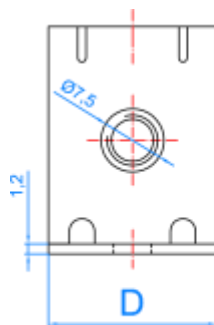

2.2 HO-CU

Horquilla pivote de cuelgue por giro



MATERIALES Y GEOMETRÍA



Galvanizado



Instalación de perfiles

CARACTERÍSTICAS

- Horquilla de giro para fijación a techo con varilla de M6.
- Para descolgar varilla roscada.
- Con rosca M6.
- Para perfil 47.
- Cumple con la EN 13964:2006

CÓDIGO	A	B	C	D	E
HOCUM647	50	25	37	49,5	22

PLANO

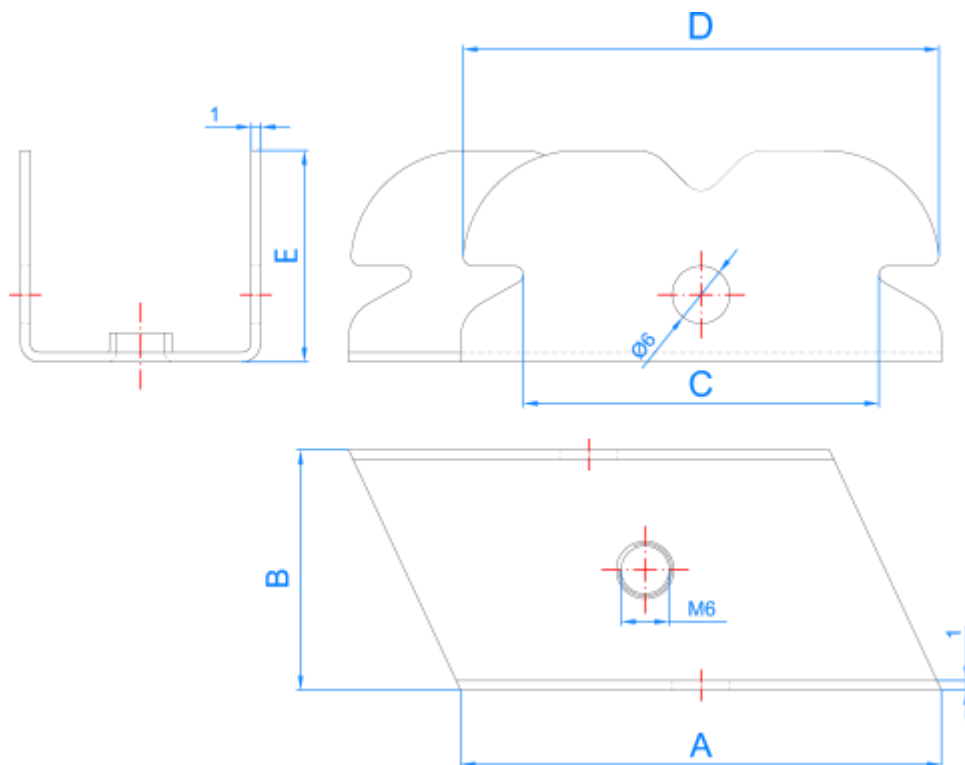

2.3 HO-CR

Horquilla de cuelgue recta

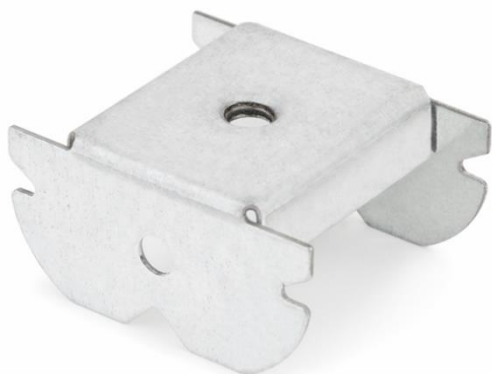

MATERIALES Y GEOMETRÍA



Galvanizado



Instalación de perfiles

CARACTERÍSTICAS

- Horquilla recta para fijación a techo con varilla M6.
- Para descolgar varilla roscada.
- Con rosca M6.
- Para perfil 47 y 60.
- Cumple con la EN 13964:2006

CÓDIGO	A	B	C	D	E
HOCRM647	43	35	35	22	28
HOCRM660	60	47	30	32,5	--

PLANO

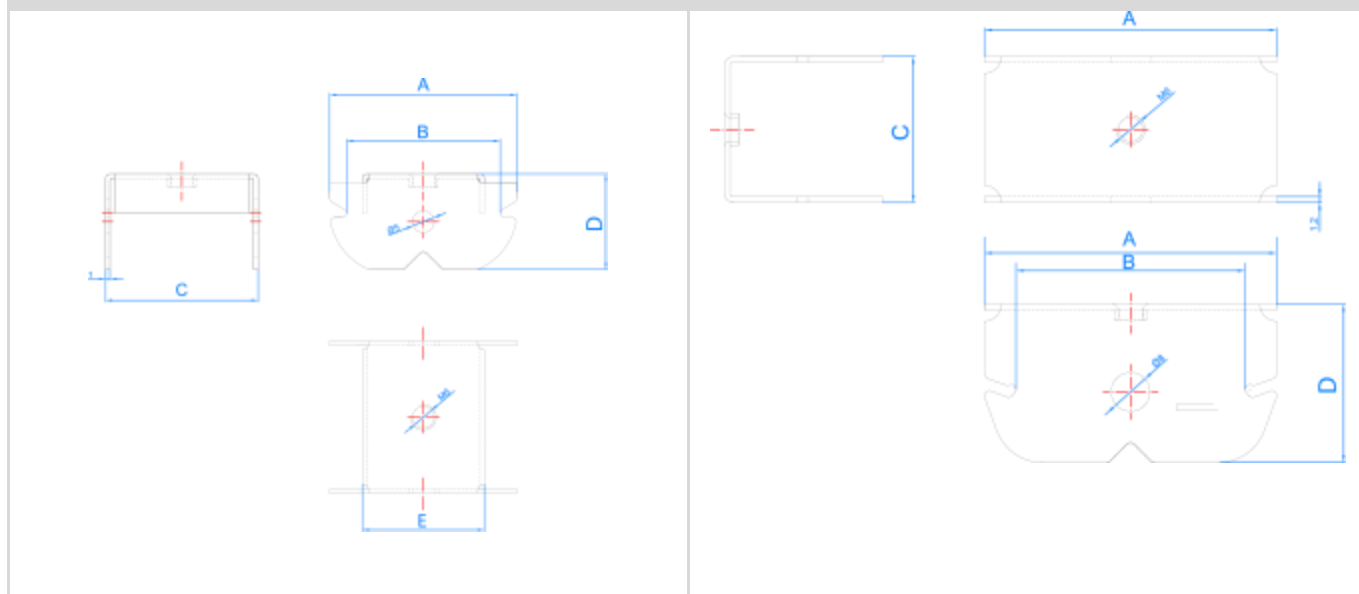

2.4 EMP

Empalme de perfiles



MATERIALES Y GEOMETRÍA



Galvanizado



Instalación de perfiles

CARACTERÍSTICAS

- Empalme para perfiles 47 y 60.
- Para unir perfiles.
- Con refuerzos.
- Cumple con la EN 13964:2006

CÓDIGO	A	B	C	D
EMPTC45	90	43	45	15,5
EMPTC47	90	45	47	14,5
EMPTC60	90	58	61	25,5

PLANO

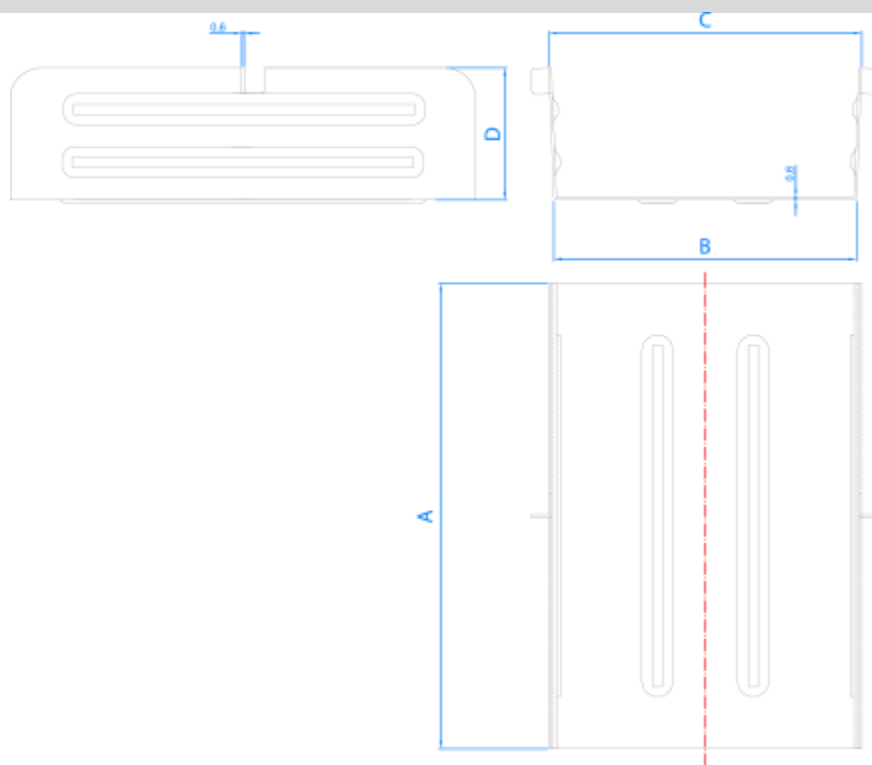

2.5 CAB

Caballete para cruce de perfiles



MATERIALES Y GEOMETRÍA



Galvanizado



Instalación de perfiles

CARACTERÍSTICAS

- Caballete para unir perfiles principales con secundarios.
- Con agujero para M6 (no roscado).
- Para perfil 47 y 60.
- Cumple con la EN 13964:2006

CÓDIGO	A	B	C	D
CABTC47	43	42,5	47,5	35
CABTC60	60	58	60	45

PLANO

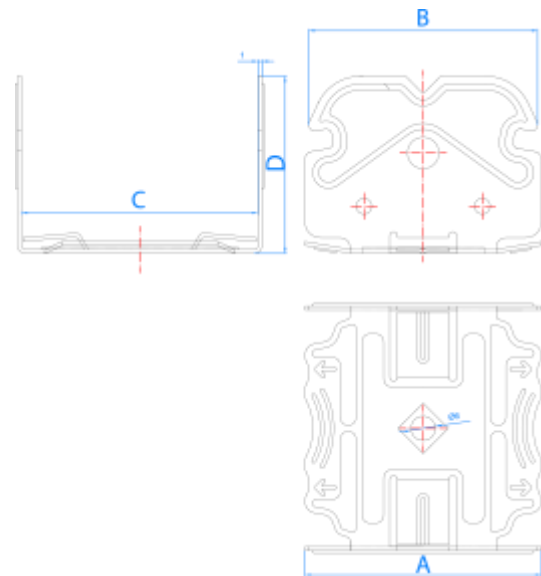
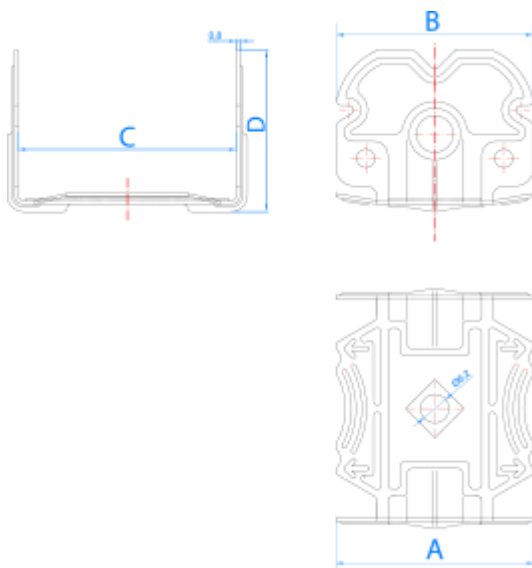

2.6 MA-BM

Media abrazadera M6 cincada



MATERIALES Y GEOMETRÍA



Cincado

CARACTERÍSTICAS

- Acabado superficial: cincado electrolítico, recubrimiento >3 micras.
- Perfil de acero.
- Adecuada para tubos de acero, plástico, cobre y ventilación.
- Indicada para instalaciones de saneamiento, eléctricas y ventilación.

CÓDIGO	A	ØD	L1	L2	H1	B
MABM6018	13	5	42	18	8,5	1,1

PLANO

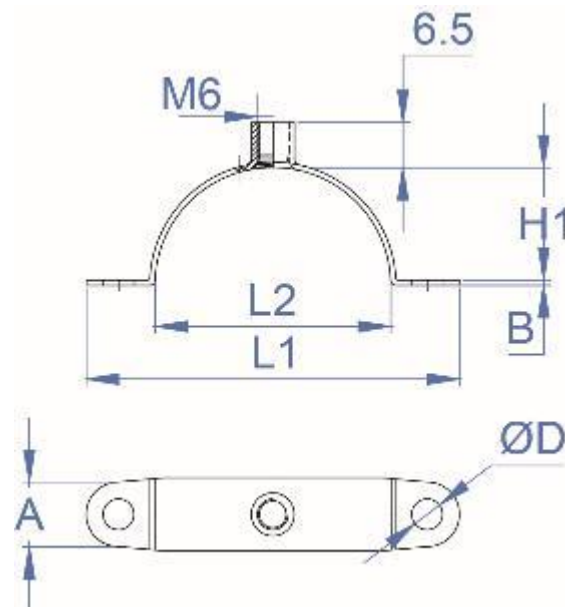

2.7 PCU

Pletina de cuelgue



Propiedades



Acero



Recubrimiento cincado

Dimensiones

Plano

CODIGO		PCU0005	PCU0006
dØ: rosca	[mm]	M8	M10
Varilla roscada		975ZM06	975ZM10

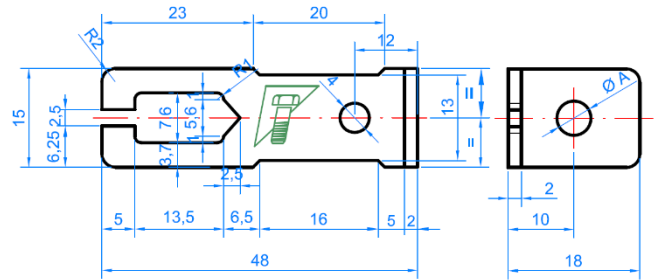

2.8 ADU

Anclaje directo "U" para fijación de perfiles



MATERIALES Y GEOMETRÍA



Galvanizado



Instalación de perfiles

CARACTERÍSTICAS

- Anclaje en U para fijar perfiles.
- Con coliso interior para fijar al techo.
- Con agujeros laterales para fijar al techo.
- Cumple con la EN 13964:2006.

CÓDIGO	A	B	C	D
ADUTC47	291	51	69	44
ADUTC60	301	61	79	44

PLANO

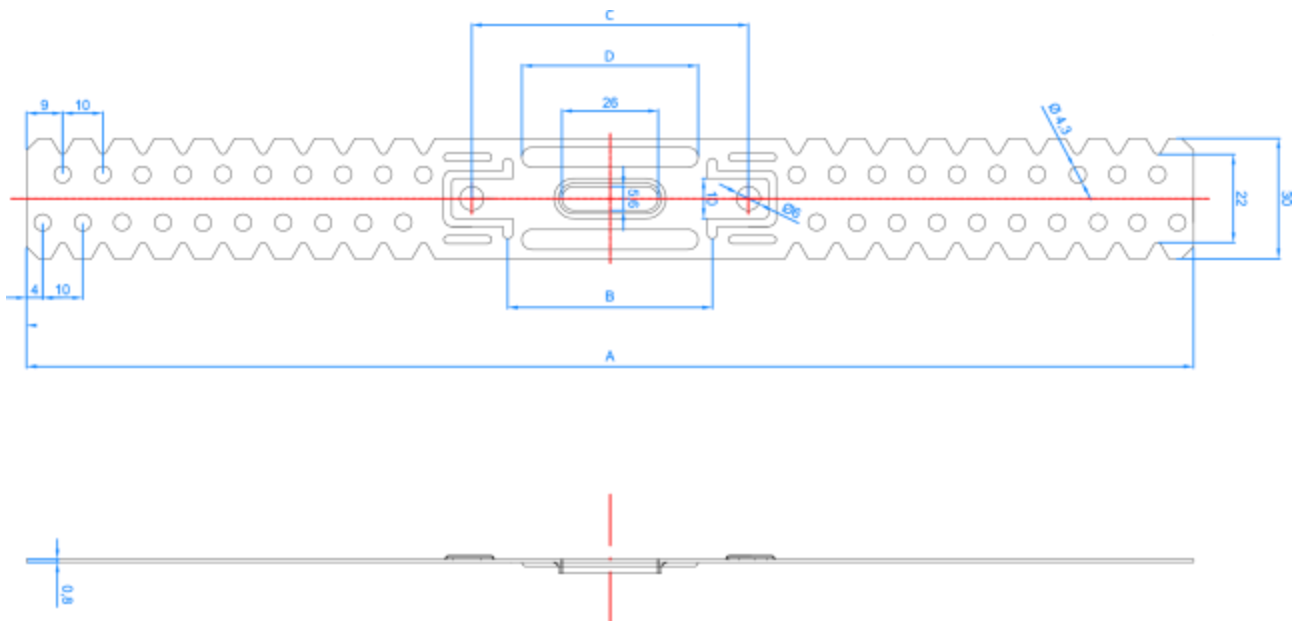

2.9 SUS

Accesorio para suspensión



MATERIALES Y GEOMETRÍA



Galvanizado



Instalación de perfiles

CARACTERÍSTICAS

- Accesorio para suspender perfiles.
- Varias longitudes.
- Con agujeros pre taladrados para unir la pieza al material base.
- Para perfil 47.
- Con patilla de seguridad (240, 300, 400)

CÓDIGO	A	B	C	D	Nº de agujeros
SUSTC47090	--	90	43	15	5
SUSTC47180	--	180	43	15	10
SUSTC47240	70	240	43	15	9
SUSTC47300	70	300	43	15	13
SUSTC47400	70	400	43	15	19

PLANO

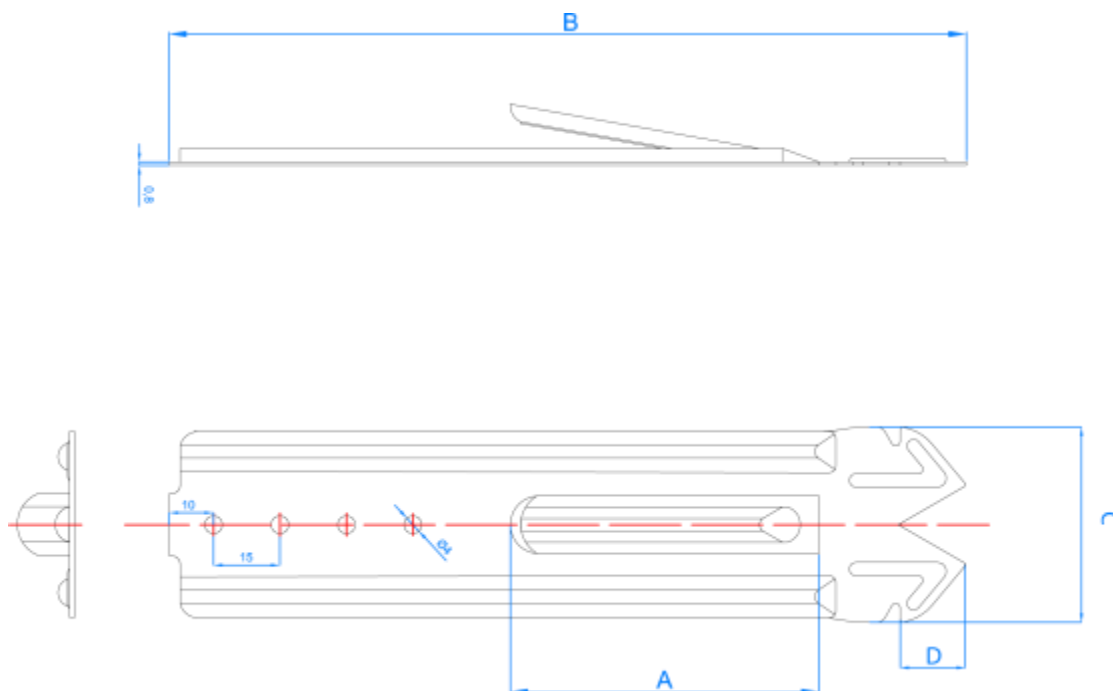

3. CARGAS MÁXIMAS RECOMENDADAS

CÓDIGO	CARGA VERTICAL [kg]	CARGA HORIZONTAL [kg]
OMEM06	154	111
HOCUM647	72	--
HOCRM647	106	--
HOCRM660	106	--
EMPTC45	--	--
EMPTC47	--	--
EMPTC60	--	--
CABTC47	71	--
CABTC60	65	--
MABM6018	70	--
ADUTC47	50	--
ADUTC60	50	--
SUSTC47090	47	--
SUSTC47180	47	--
SUSTC47240	47	--
SUSTC47300	47	--
SUSTC47400	47	--