



AB-M7 Z



AB-D7 Z



AB-71 Z



AB-71D Z



AB-PM7

**CHARACTERISTICS**

- Light heavy duty clamps for fixing plastic, copper or steel piping, wiring etc.
- Variety of formats: isophonics or standard.
- Zinc-plated coating.











**BASE MATERIAL**



**APPLICATION EXAMPLES**



1. RANGE

ITEM	PHOTO	REFERENCE	MATERIAL	COATING	SIZES [mm]	MAXIMUM LOAD RECOMMENDED [kg]	THICKNESS [mm]	WIDTH [mm]	NUT	APPLICATIONS	ISOPHONIC
1		AB-M7 Z	-		Ø8 – Ø63	25- 50 kg	0,8-1	11	Encased M7	Gas Sanitary Electrical	-
2		AB-D7 Z	-		Ø8 – Ø28	25- 50 kg	0,8-1	11	Encased M7	Gas Sanitary Electrical	-
3		AB-71 Z	-		Ø10 – Ø50	25- 50 kg	0,8-1	11	Encased M7	HSW and CW Gas Sanitary Heating Air Conditioning Electrical	✓
4		AB-71D Z	-		Ø8 – Ø28	25- 50 kg	0,8-1	11	Encased M7	HSW and CW Gas Sanitary Heating Air Conditioning Electrical	✓
5		AB-PM7	Steel Q195		-	-	-	-	-	-	-

## 2. INSTALLATION DATA

### 2.1 AB-M7 Z

### Zinc-plated M7 Clamp



#### Coating



Zinc-plated

#### Base Material



Steel pipe

Copper pipe

PVC pipe

#### Installation Data

Code	Size [mm]	Ø D (mm)	Ø D (")	A x B (mm)	Maximum Load Recommended (kg)	Characteristics
ABMZ7008	8	8	5/16"	11x0.8	25	<ul style="list-style-type: none"> <li>• For pipes from Ø8 up to Ø 63 mm.</li> <li>• Surface coating: zinc-plated ≥ 5 microns.</li> <li>• Steel profile thickness of 0.8÷1.0 mm.</li> <li>• Encased nut of M7.</li> <li>• Suitable for steel, copper and plastic pipes.</li> <li>• Appropriate for gas, sanitary and electrical installations, etc.</li> </ul>
ABMZ7010	10	10	25/64"	11x0.8	25	
ABMZ7012	12	12	15/32"	11x0.8	25	
ABMZ7014	14	14	35/64"	11x0.8	25	
ABMZ7016	16	16	5/8"	11x0.8	25	
ABMZ7018	18	18	45/64"	11x0.8	25	
ABMZ7020	20	20	25/32"	11x0.8	25	
ABMZ7022	22	22	55/64"	11x0.8	25	
ABMZ7024	24	24	15/16"	11x0.8	25	
ABMZ7025	25	25	63/64"	11x0.8	25	
ABMZ7026	26	26	1 1/32"	11x0.8	25	
ABMZ7028	28	28	1 7/64"	11x0.8	25	
ABMZ7032	32	32	1 17/64"	11x0.8	25	
ABMZ7034	34	34	1 11/32"	11x0.8	25	
ABMZ7036	36	36	1 27/64"	11x0.8	25	
ABMZ7038	38	38	1 1/2"	11x0.8	50	
ABMZ7040	40	40	1 37/64"	11x1,0	50	
ABMZ7050	50	50	1 31/32"	11x1,0	50	
ABMZ7063	63	63	2 31/64	11x1,0	50	

#### DRAWING

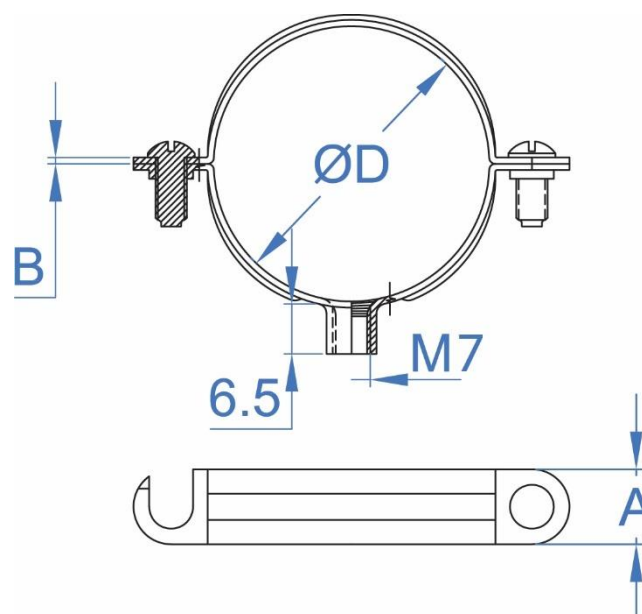

2.2

AB-D7 Z

Zinc-plated M7 Double Clamp



Coating



Zinc-plated

Base Material



Steel Pipe

Zinc-plated

Steel Pipe

Installation Data

Code	Code	Code	Code	Code	Code	Code
ABDZ70810	8-10	10	25/64"	11x0.8	25	<ul style="list-style-type: none"> <li>• For pipes from <math>\varnothing 10</math> up to <math>\varnothing 28</math> mm.</li> <li>• Surface coating: zinc-plated <math>\geq 5</math> microns.</li> <li>• Steel profile thickness of 0.8÷1.0 mm.</li> <li>• Encased nut of M7.</li> <li>• Suitable for steel, copper and plastic pipes.</li> <li>• Appropriate for gas, sanitary and electrical installations, etc.</li> </ul>
ABDZ71012	10-12	12	15/32"	11x0.8	25	
ABDZ71214	12-14	14	35/64"	11x0.8	25	
ABDZ71416	14-16	16	5/8"	11x0.8	25	
ABDZ71618	16-18	18	45/64"	11x0.8	25	
ABDZ71820	18-20	20	25/32"	11x0.8	25	
ABDZ72022	20-22	22	55/64"	11x0.8	25	
ABDZ72224	22-24	24	15/16"	11x0.8	25	
ABDZ72628	26-28	28	1 7/64"	11x0.8	25	

DRAWING

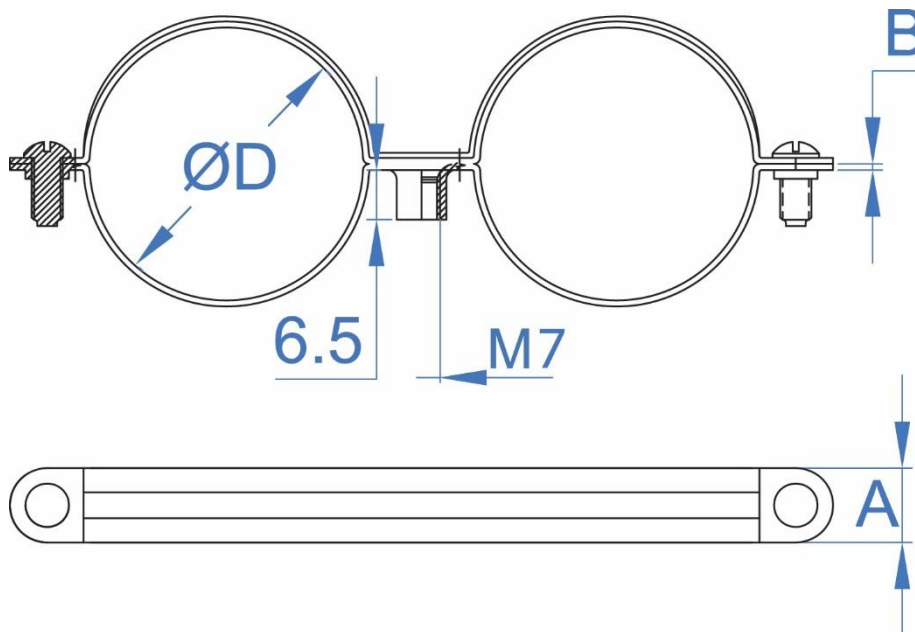

2.3

AB-D7 Z

Zinc-plated M7 Isophonic Clamp



Coating



Zinc-plated

Base Material



Steel Pipe

Zinc-plated

Steel Pipe

Installation Data

Code	Size [mm]	Ø D (mm)	Ø D (")	A x B (mm)	Maximum Load Recommended (kg)	Characteristics
AB71Z010	10	10	25/64"	11x0,8	25	<ul style="list-style-type: none"> <li>• For pipes from Ø10 up to Ø 50 mm.</li> <li>• Surface coating: zinc-plated ≥ 5 microns.</li> <li>• Steel profile thickness of 0.8÷1.0 mm.</li> <li>• Encased nut of M7.</li> <li>• EPDM rubber for isolation and noise / vibration reduction</li> <li>• Suitable for steel, copper and plastic pipes.</li> <li>• Appropriate for gas, sanitary and electrical installations, etc.</li> </ul>
AB71Z012	12	12	15/32"	11x0,8	25	
AB71Z014	14	14	35/64"	11x0,8	25	
AB71Z016	16	16	5/8"	11x0,8	25	
AB71Z018	18	18	45/64"	11x0,8	25	
AB71Z020	20	20	25/32"	11x0,8	25	
AB71Z022	22	22	55/64"	11x0,8	25	
AB71Z024	24	24	15/16"	11x0,8	25	
AB71Z026	26	26	1 1/32"	11x0,8	25	
AB71Z028	28	28	1 7/64"	11x0,8	25	
AB71Z032	32	32	1 17/64"	11x0,8	25	
AB71Z034	34	34	1 11/32"	11x0,8	25	
AB71Z036	36	36	1 27/64"	12x1,0	25	
AB71Z038	38	38	1 1/2"	12x1,0	50	
AB71Z040	40	40	1 37/64"	12x1,0	50	
AB71Z050	50	50	1 31/32"	12x1,0	50	

DRAWING

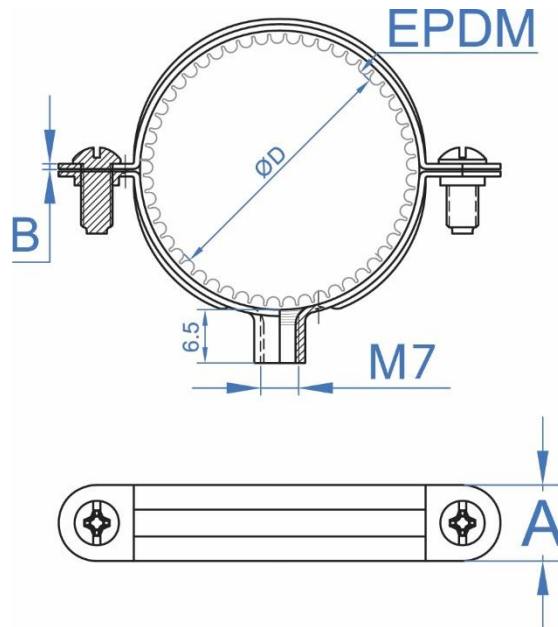

2.4

AB-D7 Z

Zinc-plated M7 Double Isophonic Clamp



Coating



Zinc-plated

Base Material



Steel Pipe

Copper Pipe

PVC Pipe

Installation Data

Code	Size [mm]	Ø D (mm)	Ø D (")	A x B (mm)	Maximum Load Recommended (kg)	Characteristics
AB71DZ0810	08-10	10	25/64"	11x0,8	25	<ul style="list-style-type: none"> <li>• For pipes from Ø10 up to Ø 28 mm.</li> <li>• Surface coating: zinc-plated ≥ 5 microns.</li> <li>• Steel profile thickness of 0.8÷1.0 mm.</li> <li>• Encased nut of M7.</li> <li>• EPDM rubber for isolation and noise / vibration reduction</li> <li>• Suitable for steel, copper and plastic pipes.</li> <li>• Appropriate for gas, sanitary and electrical installations, etc.</li> </ul>
AB71DZ1012	10-12	12	15/32"	11x0,8	25	
AB71DZ1214	12-14	14	35/64"	11x0,8	25	
AB71DZ1416	14-16	16	5/8"	11x0,8	25	
AB71DZ1618	16-18	18	45/64"	11x0,8	25	
AB71DZ1820	18-20	20	25/32"	11x0,8	25	
AB71DZ2022	20-22	22	55/64"	11x0,8	25	
AB71DZ2224	22-24	24	15/16"	11x0,8	25	
AB71DZ2628	26-28	28	1 1/32"	11x0,8	25	

DRAWING

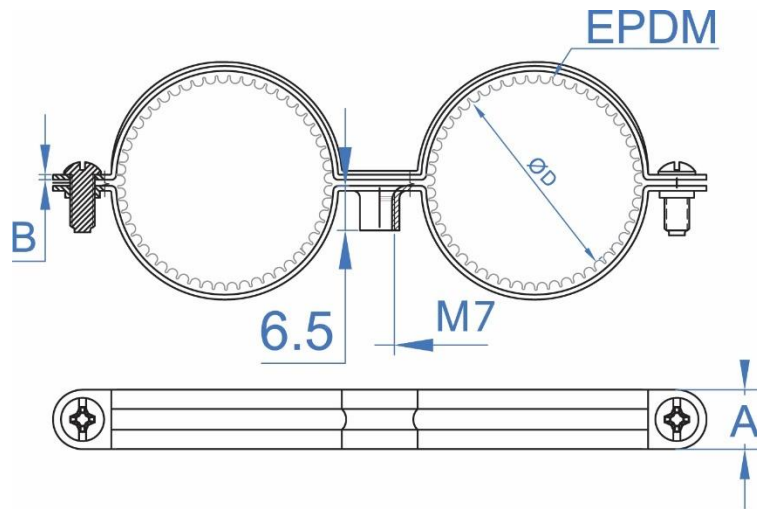

## 2.5 AB-PM7

### Cylindrical spacer for clamps M7



#### Properties



Steel



Zin Plated coating

#### Sizes

Code	A	B	C
ABPM720	20	8	11
ABPM730	30	8	12
ABPM740	40	8	13

#### DRAWING

