

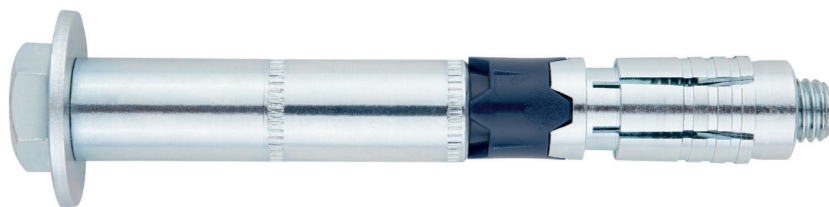

Safe anchor for heavy-duty loads, for use in cracked and non cracked concrete

SL-PT

ETA Assessment Option 1. Zinc-plated steel. Antispin made of polyamide.



PRODUCT INFORMATION

DESCRIPTION

Metallic anchor for heavy duty loads expansion by controlled torque.

OFFICIAL DOCUMENTATION

- CE-1219-CPR-0219.
- ETA 18/1108 option 1.
- Declaration of Performance DoP SL.

SIZES

M6x70 to M20x240.

DESIGN LOAD RANGE

Desde 10,0 to 45,83 kN [non cracked]
Desde 8,1 to 32,08 kN [cracked].



BASE MATERIAL

Concrete class from C20/25 to C50/60
cracked or non-cracked.



Stone

Concrete

Reinforced concrete

Cracked concrete

ASSESSMENTS

- Option 1 [Cracked and non-cracked concrete].
- Fire Resistance R30-120.



CHARACTERISTICS AND BENEFITS

- Easy installation.
- Use in cracked and non-cracked concrete.
- Use for heavy duty loads.
- Installation through the drill-hole of the fixture.
- It can be disassembled leaving the surface clear [the expander and the cone remain inside the hole].
- Available at INDEXcal.



MATERIALS

Bolt SL-PT: Grade 8.8 ISO 898-1, zinc-plated $\geq 5 \mu\text{m}$.
 Bolt SL-PC: Grade 10.9 ISO 898-1, zinc-plated $\geq 5 \mu\text{m}$.
 Stud SL-PE: Grade 8.8 ISO 898-1, zinc-plated $\geq 5 \mu\text{m}$.
 Washer: DIN 9021 Carbon steel, zinc-plated $\geq 5 \mu\text{m}$.
 Sleeve: Carbon steel, zinc-plated $\geq 5 \mu\text{m}$.
 Expander: Carbon steel, zinc-plated $\geq 5 \mu\text{m}$.
 Cone: Carbon steel, zinc-plated $\geq 5 \mu\text{m}$.



Antispin: Nylon.



APPLICATIONS

- Structural interior fixing in concrete
- Fixing pillars and beams.
- Fixing beams, rails, machinery, shelves, scaffolding and corbels.
- Application where fire or seismic effects must be taken into account.





MECHANICAL PROPERTIES

			M6	M8	M10	M12	M16	M20
Bolt 8.8								
A_s	(mm ²)	Threaded area section	20,1	36,6	58	84,3	157	245
$f_{u,s}$	(N/mm ²)	Characteristic tension resistance	800	800	800	800	800	800
$f_{y,s}$	(N/mm ²)	Yield Strength	640	640	640	640	640	640
Bolt 10.9								
A_s	(mm ²)	Threaded area section	20,1	36,6	58	84,3	157	245
$f_{u,s}$	(N/mm ²)	Characteristic tension resistance	1000	1000	1000	1000	1000	1000
$f_{y,s}$	(N/mm ²)	Yield Strength	900	900	900	900	900	900

INSTALLATION DATA

METRIC			M6	M8	M10	M12	M16	M20
Code			SLPX06XXX	SLPX08XXX	SLPX10XXX	SLPX12XXX	SLPX16XXX	SLPX20XXX
d_0	Nominal diameter of drill bit	[mm]	10	12	16	18	24	28
T_{ins}	Installation torque moment	[Nm]	15	30	50	80	160	240
$d_{f \leq}$	Diameter of clearance hole in the fixture	[mm]	12	14	18	20	26	31
h_1	Minimum drill hole depth	[mm]	70	85	95	110	130	160
h_{nom}	Installation depth	[mm]	59	72	83	97	117	146
h_{ef}	Effective embedment depth	[mm]	50	60	70	85	100	125
h_{min}	Minimum base material thickness	[mm]	100	120	140	170	200	250
t_{fix}	Maximum thickness of fixture	[mm]	L - 60	L - 75	L - 85	L - 100	L - 120	L - 150
$s_{cr,N}$	Critical spacing	[mm]	150	180	210	255	300	375
$c_{cr,N}$	Critical edge distance	[mm]	75	90	105	128	150	188
$s_{cr,sp}$	Critical distance (splitting)	[mm]	205	245	285	345	410	510
$c_{cr,sp}$	Critical edge distance (splitting)	[mm]	105	125	145	175	205	255
s_{min}	Minimum spacing	[mm]	100	120	175	200	220	320
c_{min}	Minimum edge distance	[mm]	50	60	70	80	100	160
SW	Installation wrench	SL-PT SL-PE	10	13	17	19	24	30
SW	Installation wrench	SL-PC	4	5	6	8	10	12

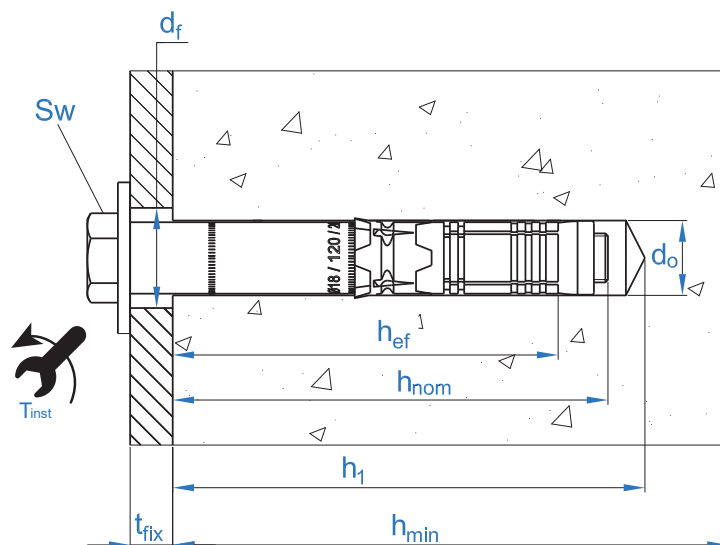



Code	INSTALLATION PRODUCTS
	Hammer drill
BHDSXXXXX	Concrete Drill bits
MOBOMBA	Blow pump
MORCEPKIT	Cleaning Brush
DOMTAXX	Installation hammering tool
	Torque wrench
	Hexagonal socket

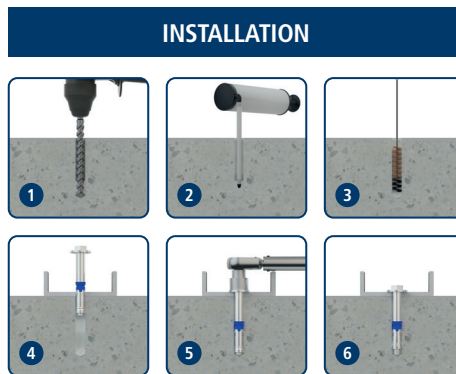

SL-PT

Resistances in C20/25 concrete for an isolated anchor, without effects of edge distance or spacing

Characteristic Resistance N_{Rk} and V_{Rk}															
TENSION							SHEAR								
Size		M6	M8	M10	M12	M16	M20	Size		M6	M8	M10	M12	M16	M20
N_{Rk}	Non-cracked concrete [kN]	15,0	20,0	28,8	38,6	49,2	68,8	V_{Rk}	Non-cracked concrete [kN]	20,2	33,0	62,2	75,1	111,2	141,7
N_{Rk}	Cracked concrete [kN]	12,2	16,0	20,2	27,0	34,4	48,1	V_{Rk}	Cracked concrete [kN]	20,2	33,0	68,6	75,1	111,2	141,7

Design Resistance N_{Rd} and V_{Rd}															
TENSION							SHEAR								
Size		M6	M8	M10	M12	M16	M20	Size		M6	M8	M10	M12	M16	M20
N_{Rd}	Non-cracked concrete [kN]	10,0	13,3	19,2	25,7	32,8	45,9	V_{Rd}	Non-cracked concrete [kN]	16,2	26,4	49,8	60,1	89,0	113,4
N_{Rd}	Cracked concrete [kN]	8,1	10,7	13,5	18,0	22,9	32,1	V_{Rd}	Cracked concrete [kN]	16,2	26,4	45,7	60,1	89,0	113,4

Maximum Loads Recommended N_{rec} and V_{rec}															
TENSION							SHEAR								
Size		M6	M8	M10	M12	M16	M20	Size		M6	M8	M10	M12	M16	M20
N_{rec}	Non-cracked concrete [kN]	7,1	9,5	13,7	18,4	23,4	32,8	V_{rec}	Non-cracked concrete [kN]	11,5	18,9	35,5	42,9	63,5	81,0
N_{rec}	Cracked concrete [kN]	5,8	7,6	9,6	12,9	16,4	22,9	V_{rec}	Cracked concrete [kN]	11,6	18,9	32,7	42,9	63,6	81,0

Simplified calculation method

European Technical Assessment ETA 12/0397

Simplified version of the calculation method according to Eurocode 2 EN 1992-4. Resistance is calculated according to the data shown in assessment 18/1108.

- Influence of concrete strength.
- Influence of edge distance.
- Influence of spacing between anchors.
- Influence of reinforcements.
- Influence of base material thickness.
- Influence of load application angle.
- Valid for a group of two anchors.



INDEXcal

For a more accurate calculation and to take more constructive provisions into account, we recommend using our calculation program INDEXcal. It may be easily downloaded from our website www.indexfix.com



SL-PT

TENSION LOADS

- Steel design resistance: $N_{Rd,s}$
- Pull-out design resistance: $N_{Rd,p} = N_{Rd,p}^o \cdot \Psi_c$
- Concrete cone design resistance: $N_{Rd,c} = N_{Rd,c}^o \cdot \Psi_b \cdot \Psi_{s,N} \cdot \Psi_{c,N} \cdot \Psi_{re,N}$
- Concrete splitting design resistance: $N_{Rd,sp} = N_{Rd,c}^o \cdot \Psi_b \cdot \Psi_{s,sp} \cdot \Psi_{c,sp} \cdot \Psi_{re,N} \cdot \Psi_{h,sp}$

Steel Design resistance			$N_{Rd,s}$					
Metric			M6	M8	M10	M12	M16	M20
N_{Rd}^o	Non-cracked concrete	[kN]	10,7	19,5	30,9	44,9	84,0	130,7

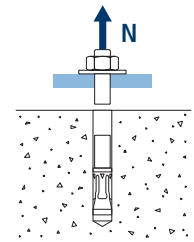

Pull-out design resistance			$N_{Rd,p} = N_{Rd,p}^o \cdot \Psi_c$					
Metric			M6	M8	M10	M12	M16	M20
$N_{Rd,p}^o$	Non-cracked concrete	[kN]	10,0	13,3	-*	-*	-*	-*
$N_{Rd,p}^o$	Cracked concrete	[kN]	-*	-*	-*	-*	-*	-*

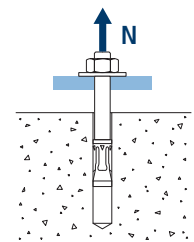

* Pull-out failure is not decisive.

Concrete cone design resistance			$N_{Rd,c} = N_{Rd,c}^o \cdot \Psi_b \cdot \Psi_{s,N} \cdot \Psi_{c,N} \cdot \Psi_{re,N}$					
Concrete splitting design resistance*			$N_{Rd,sp} = N_{Rd,c}^o \cdot \Psi_b \cdot \Psi_{s,sp} \cdot \Psi_{c,sp} \cdot \Psi_{re,N} \cdot \Psi_{h,sp}$					
Metric			M6	M8	M10	M12	M16	M20
$N_{Rd,c}^o$	Non-cracked concrete	[kN]	11,6	15,2	19,2	25,7	32,8	45,8
$N_{Rd,c}^o$	Cracked concrete	[kN]	8,1	10,7	13,4	18,0	23,0	32,1

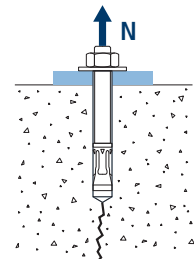
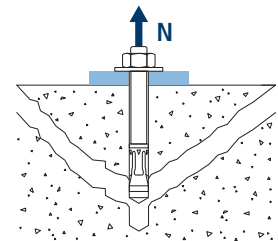

*Concrete splitting design resistance must only be considered for non-cracked concrete.



SL-PT

Coefficients of influence

Influence of concrete strength resistance in pul-out failure Ψ_c

		M6	M8	M10	M12	M16	M20
Ψ_c	C 20/25	1,00					
	C 30/37	1,22	1,22	1,22	1,22	1,08	1,08
	C 40/50	1,41	1,41	1,41	1,41	1,15	1,15
	C 50/60	1,58	1,58	1,58	1,58	1,20	1,20

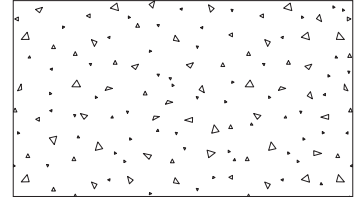
Influence of concrete strength in concret cone and splitting failure Ψ_b

		M6	M8	M10	M12	M16	M20
Ψ_b	C 20/25	1,00					
	C 30/37	1,22					
	C 40/50	1,41					
	C 50/60	1,55					

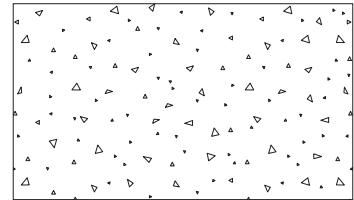

$$\Psi_b = \sqrt{\frac{f_{ck,cube}}{25}} \geq 1$$



SL-PT

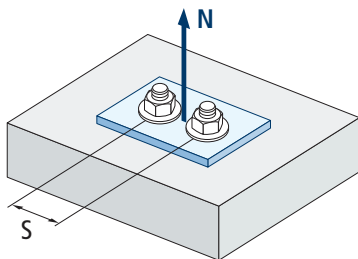

$$\psi_{s,N} = 0,5 + \frac{s}{2 \cdot s_{cr,N}} \leq 1$$

Influence of spacing (concrete cone) $\psi_{s,N}$						
s [mm]	SL-PT					
	M6	M8	M10	M12	M16	M20
100	0,83					
110	0,87					
120	0,90	0,83				
130	0,93	0,86				Invalid value
140	0,97	0,89				
150	1,00	0,92				
160		0,94				
175		0,99	0,92			
180		1,00	0,93			
200			0,98	0,89		
205			0,99	0,90		
210			1,00	0,91		
220				0,93	0,87	
245				0,98	0,91	
250				0,99	0,92	
255				1,00	0,93	
285					0,98	
300					1,00	
320						0,93
345						0,96
375						1,00

Value without reduction = 1



Influence of spacing (concrete splitting) $\psi_{s,sp}$						
s [mm]	SL-PT					
	M6	M8	M10	M12	M16	M20
100	0,74					
110	0,77					
120	0,79	0,74				
130	0,82	0,77				
140	0,84	0,79				
150	0,87	0,81				
160	0,89	0,83				
175	0,93	0,86	0,81			
180	0,94	0,87	0,82			
200	0,99	0,91	0,85	0,79		
205	1,00	0,92	0,86	0,80		
210		0,93	0,87	0,80		
220		0,95	0,89	0,82	0,77	
245		1,00	0,93	0,86	0,80	
250			0,94	0,86	0,80	
255			0,95	0,87	0,81	
285			1,00	0,91	0,85	
300				0,93	0,87	
320				0,96	0,89	0,81
345				1,00	0,92	0,84
375					0,96	0,87
410					1,00	0,90
510						1,00

Invalid value

Value without reduction = 1

SL-PT

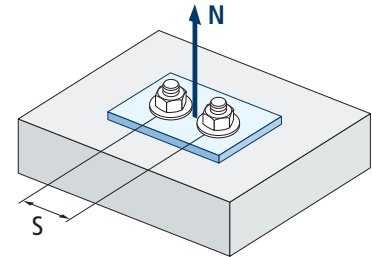

$$\psi_{s,sp} = 0,5 + \frac{s}{2 \cdot s_{cr,sp}} \leq 1$$



SL-PT

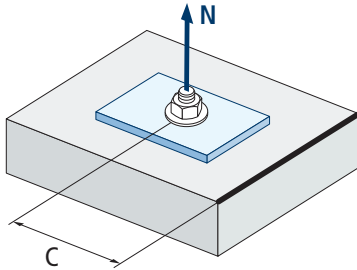

$$\psi_{c,sp} = 0,35 + \frac{0,5 \cdot c}{C_{cr,sp}} + \frac{0,15 \cdot c^2}{C_{cr,sp}^2} \leq 1$$

Influence of concrete edge distance (splitting) $\psi_{c,sp}$						
s [mm]	SL-PT					
	M6	M8	M10	M12	M16	M20
50	0,62					
60	0,68	0,62				
70	0,75	0,68	0,63			Invalid value
75	0,78	0,70	0,65			
80	0,82	0,73	0,67	0,61		
90	0,89	0,79	0,72	0,65		
100	0,96	0,85	0,77	0,68	0,63	
105	1,00	0,88	0,79	0,70	0,65	
110	1,04	0,91	0,82	0,72	0,66	
120	1,12	0,97	0,87	0,76	0,69	
125		1,00	0,89	0,78	0,71	
128			0,91	0,80	0,72	
130			0,92	0,80	0,73	
140			0,97	0,85	0,76	
145			1,00	0,87	0,78	
150				0,89	0,80	
160				0,93	0,83	0,72
170				0,98	0,87	0,75
175				1,00	0,89	0,76
188					0,93	0,80
205					1,00	0,85
220						0,89
255						1,00

Value without reduction = 1



Influence of concrete edge distance (concrete cone) $\psi_{c,N}$						
s [mm]	SL-PT					
	M6	M8	M10	M12	M16	M20
50	0,75					
60	0,85	0,75				
70	0,95	0,83	0,75			
75	1,00	0,87	0,78			
80		0,91	0,82	0,72		
90		1,00	0,89	0,78		
100			0,96	0,83	0,75	
105			1,00	0,86	0,77	
110				0,89	0,80	
120				0,95	0,85	
125				0,98	0,87	
128				1,00	0,89	
130					0,90	
140					0,95	
145					0,97	
150					1,00	
160						0,88
170						0,92
175						0,95
188						1,00

SL-PT

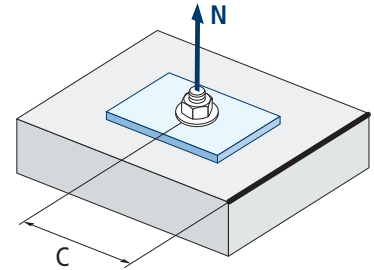

$$\psi_{c,N} = 0,35 + \frac{0,5 \cdot c}{c_{cr,N}} + \frac{0,15 \cdot c^2}{c_{cr,N}^2} \leq 1$$

Influence of reinforcements $\psi_{re,N}$						
$\psi_{re,N}$	SL-PT					
	M6	M8	M10	M12	M16	M20
	0,75	0,8	0,85	1,00	1,00	1,00

*This factor only applies for a high density of reinforcements. If in the area of the anchor there are reinforcements with a distancing of ≥ 150 mm (any diameter) or with a diameter ≤ 10 mm and a distancing of ≥ 100 mm, a $f_{re,N} = 1$ factor may be applied.

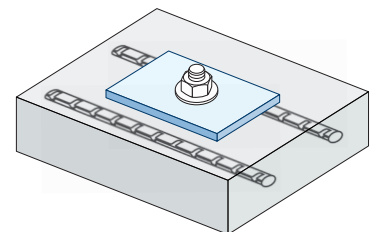

$$\psi_{re,N} = 0,5 + \frac{h_{ef}}{200} \leq 1$$

Influence of base material thickness $\psi_{h,sp}$											
$\psi_{h,sp}$	SL-PT										
	h/h _{ef}	2,00	2,20	2,40	2,60	2,80	3,00	3,20	3,40	3,60	$\geq 3,68$
	f _h	1,00	1,07	1,13	1,19	1,25	1,31	1,37	1,42	1,48	1,50

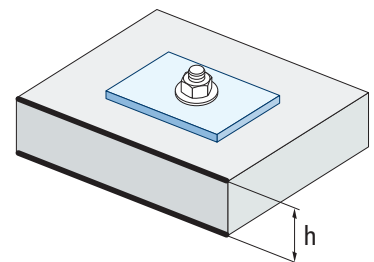

$$\psi_{h,sp} = \left(\frac{h}{2 \cdot h_{ef}} \right)^{2/3} \leq 1,5$$



SL-PT

SHEAR LOADS

- Steel design resistance without lever arm: $V_{Rd,s}$
- Pry-out design resistance: $V_{Rd,cp} = k \cdot N_{Rd,c}^o$
- Concrete edge design resistance: $V_{Rd,c} = V_{Rd,c}^o \cdot \psi_b \cdot \psi_{se,V} \cdot \psi_{c,V} \cdot \psi_{re,V} \cdot \psi_{\alpha,V} \cdot \psi_{h,V}$

Steel design resistance							
$V_{Rd,s}$							
Metric		M6	M8	M10	M12	M16	M20
$V_{Rd,s}$	[kN]	16,16	26,4	49,76	60,08	88,96	113,36

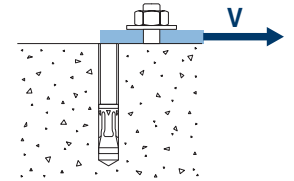

Pry-out design resistance*							
$V_{Rd,cp} = k \cdot N_{Rd,c}^o$							
Metric		M6	M8	M10	M12	M16	M20
k		3,2	3,0	3,4	3,6	4,3	4,3

* $N_{Rd,c}^o$ Concrete cone design resistance for tension loads

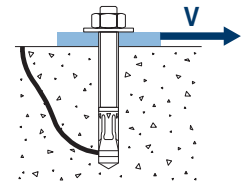

Concrete edge resistance								
$V_{Rd,c} = V_{Rd,c}^o \cdot \psi_b \cdot \psi_{se,V} \cdot \psi_{c,V} \cdot \psi_{re,V} \cdot \psi_{\alpha,V} \cdot \psi_{h,V}$								
Metric		M6	M8	M10	M12	M16	M20	
$V_{Rd,c}^o$	Non-cracked concrete	[kN]	6,5	8,8	11,4	15,8	20,5	29,9
	Cracked concrete	[kN]	4,6	6,3	8,1	11,3	14,6	21,4

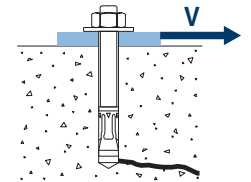



SL-PT

Coefficients of influence

Influence of concrete strength in concrete edge failure Ψ_b

		M6	M8	M10	M12	M16	M20	
Ψ_b	C 20/25	1,00						
	C 30/37	1,22						
	C 40/50	1,41						
	C 50/60	1,55						

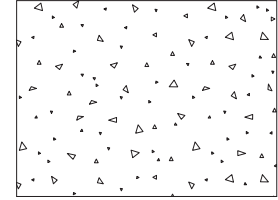

$$\Psi_b = \sqrt{\frac{f_{ck,cube}}{25}} \geq 1$$

Influence of edge distance and spacing $\Psi_{se,V}$

FOR ONE ANCHOR ONLY

c/h_{ef}	0,50	0,75	1,00	1,25	1,50	1,75	2,00	2,25	2,50	2,75	3,00	3,25	3,50	3,75	4,00	4,50	5,00
Isolated	0,35	0,65	1,00	1,40	1,84	2,32	2,83	3,38	3,95	4,56	5,20	5,86	6,55	7,26	8,00	9,55	11,18

FOR TWO ANCHORS

c/h_{ef}	0,50	0,75	1,00	1,25	1,50	1,75	2,00	2,25	2,50	2,75	3,00	3,25	3,50	3,75	4,00	4,50	5,00	
s/c	1,0	0,24	0,43	0,67	0,93	1,22	1,54	1,89	2,25	2,64	3,04	3,46	3,91	4,37	4,84	5,33	6,36	7,45
	1,5	0,27	0,49	0,75	1,05	1,38	1,74	2,12	2,53	2,96	3,42	3,90	4,39	4,91	5,45	6,00	7,16	8,39
	2,0	0,29	0,54	0,83	1,16	1,53	1,93	2,36	2,81	3,29	3,80	4,33	4,88	5,46	6,05	6,67	7,95	9,32
	2,5	0,32	0,60	0,92	1,28	1,68	2,12	2,59	3,09	3,62	4,18	4,76	5,37	6,00	6,66	7,33	8,75	10,25
	≥ 3,0	0,35	0,65	1,00	1,40	1,84	2,32	2,83	3,38	3,95	4,56	5,20	5,86	6,55	7,26	8,00	9,55	11,18

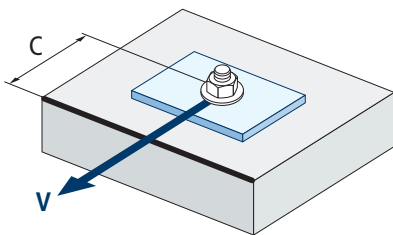

$$\Psi_{se,V} = \left(\frac{c}{h_{ef}}\right)^{1,5}$$

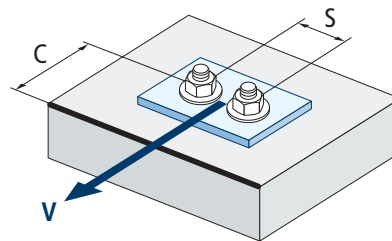

$$\Psi_{se,V} = \left(\frac{c}{h_{ef}}\right)^{1,5} \cdot \left(1 + \frac{s}{3 \cdot c}\right) \cdot 0,5 \leq \left(\frac{c}{h_{ef}}\right)^{1,5}$$



SL-PT

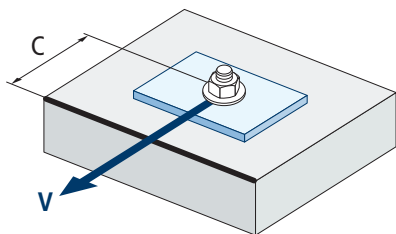

$$\psi_{c,v} = \left(\frac{d}{c} \right)^{0,20}$$

Influence of concrete edge distance $\psi_{c,v}$						
s [mm]	SL-PT					
	M6	M8	M10	M12	M16	M20
50	0,72					
55	0,71					
60	0,70	0,72				
70	0,68	0,70	0,74			
80	0,66	0,68	0,72			
85	0,65	0,68	0,72	0,73		
90	0,64	0,67	0,71	0,72		
100	0,63	0,65	0,69	0,71	0,75	
105	0,62	0,65	0,69	0,70	0,74	
110	0,62	0,64	0,68	0,70	0,74	
120	0,61	0,63	0,67	0,68	0,72	
125	0,60	0,63	0,66	0,68	0,72	0,74
128	0,60	0,62	0,66	0,68	0,72	0,74
130	0,60	0,62	0,66	0,67	0,71	0,74
135	0,59	0,62	0,65	0,67	0,71	0,73
140	0,59	0,61	0,65	0,66	0,70	0,72
150	0,58	0,60	0,64	0,65	0,69	0,71
160	0,57	0,60	0,63	0,65	0,68	0,71
170	0,57	0,59	0,62	0,64	0,68	0,70
175	0,56	0,59	0,62	0,63	0,67	0,69
180	0,56	0,58	0,62	0,63	0,67	0,69
190	0,55	0,58	0,61	0,62	0,66	0,68
200	0,55	0,57	0,60	0,62	0,65	0,67
210	0,54	0,56	0,60	0,61	0,65	0,67
220	0,54	0,56	0,59	0,61	0,64	0,66
230	0,53	0,55	0,59	0,60	0,64	0,66
240	0,53	0,55	0,58	0,60	0,63	0,65
250	0,53	0,54	0,58	0,59	0,63	0,65
260	0,52	0,54	0,57	0,59	0,62	0,64
270	0,52	0,54	0,57	0,58	0,62	0,64
280	0,51	0,53	0,56	0,58	0,61	0,63
290	0,51	0,53	0,56	0,57	0,61	0,63
300	0,51	0,53	0,56	0,57	0,60	0,62

Influence of reinforcements $\Psi_{re,v}$

	Without perimetral reinforcements	Perimetral reinforcements $\geq \text{Ø}12 \text{ mm}$	Perimetral reinforcements with brackets $\leq 100 \text{ mm}$
Non-cracked concrete	1	1	1
Cracked concrete	1	1,2	1,4

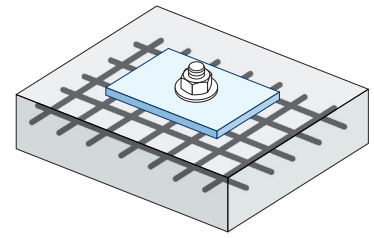
Influence of load application angle $\Psi_{\alpha,v}$

Angle, $\alpha(^{\circ})$	0°	10°	20°	30°	40°	50°	60°	70°	80°	90°
$\Psi_{\alpha,v}$	1,00	1,01	1,05	1,13	1,24	1,40	1,64	1,97	2,32	2,50

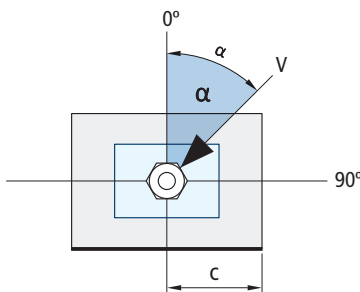

$$\Psi_{\alpha,v} = \sqrt{\frac{1}{(\cos \alpha_v)^2 + \left(\frac{\sin \alpha_v}{2,5}\right)^2}} \geq 1$$

Influence of base material thickness $\Psi_{h,v}$

SL-PT										
h/c	0,15	0,30	0,45	0,60	0,75	0,90	1,05	1,20	1,35	$\geq 1,5$
$\Psi_{h,v}$	0,32	0,45	0,55	0,63	0,71	0,77	0,84	0,89	0,95	1,00

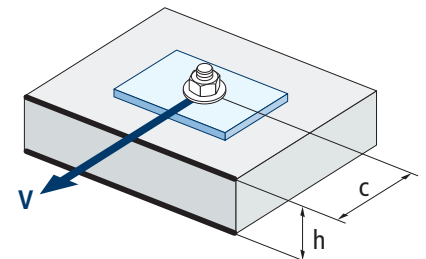

$$\Psi_{h,v} = \left(\frac{h}{1,5 \cdot c}\right)^{0,5} \geq 1,0$$



SL-PT

RANGE

SL-PT



Code	Size	Maximum thickness of fixture		
SLPT10070	M6 x 70 Ø10	10	50	600
SLPT10080	M6 x 80 Ø10	20	50	600
SLPT10100	M6 x 100 Ø10	40	50	300
SLPT10110	M6 x 110 Ø10	50	25	150
SLPT12080	M8 x 80 Ø12	5	50	300
SLPT12090	M8 x 90 Ø12	15	50	200
SLPT12100	M8 x 100 Ø12	25	50	200
SLPT12120	M8 x 120 Ø12	45	25	200
SLPT16100	M10 x 100 Ø16	15	25	150
SLPT16120	M10 x 120 Ø16	35	25	100
SLPT16140	M10 x 140 Ø16	55	20	60
SLPT16160	M10 x 160 Ø16	75	20	60
SLPT18110	M12 x 110 Ø18	10	20	80

Code	Size	Maximum thickness of fixture		
SLPT18120	M12 x 120 Ø18	20	20	80
SLPT18140	M12 x 140 Ø18	40	20	80
SLPT18150	M12 x 150 Ø18	50	20	80
SLPT18170	M12 x 170 Ø18	70	15	45
SLPT18200	M12 x 200 Ø18	100	15	30
SLPT24140	M16 x 140 Ø24	20	10	40
SLPT24170	M16 x 170 Ø24	50	10	30
SLPT24200	M16 x 200 Ø24	80	10	20
SLPT24220	M16 x 220 Ø24	100	10	20
SLPT28170	M20 x 170 Ø28	20	10	20
SLPT28200	M20 x 200 Ø28	50	10	20
SLPT28240	M20 x 240 Ø28	90	5	10

SL-PC



Code	Size	Maximum thickness of fixture		
SLPC10070	M6 x 70 Ø10	10	50	600
SLPC10080	M6 x 80 Ø10	20	50	600
SLPC10100	M6 x 100 Ø10	40	50	300
SLPC12100	M8 x 100 Ø12	25	50	200

Code	Size	Maximum thickness of fixture		
SLPC16100	M10 x 100 Ø16	15	25	150
SLPC16120	M10 x 120 Ø16	35	25	100
SLPC18120	M12 x 120 Ø18	20	20	80

SL-PE



Code	Size	Maximum thickness of fixture		
SLPE12095	M8 X 95 Ø12	20	50	200
SLPE12155	M8 X 155 Ø12	80	25	100
SLPE16125	M10 X 125 Ø16	40	25	100
SLPE16160	M10 X 160 Ø16	75	20	60
SLPE16245	M10 X 245 Ø16	160	10	20
SLPE18150	M12 X 150 Ø18	50	20	40
SLPE18170	M12 X 170 Ø18	70	15	45
SLPE18260	M12 X 260 Ø18	160	5	10

Code	Size	Maximum thickness of fixture		
SLPE24145	M16 X 145 Ø24	25	10	40
SLPE24170	M16 X 170 Ø24	50	10	30
SLPE24200	M16 X 200 Ø24	80	10	20
SLPE24280	M16 X 280 Ø24	160	5	10
SLPE28210	M20 X 210 Ø28	60	5	10
SLPE28230	M20 X 230 Ø28	80	5	10
SLPE28310	M20 X 310 Ø28	160	5	10