

**Declaration of Performance  
DoP TEC-en**

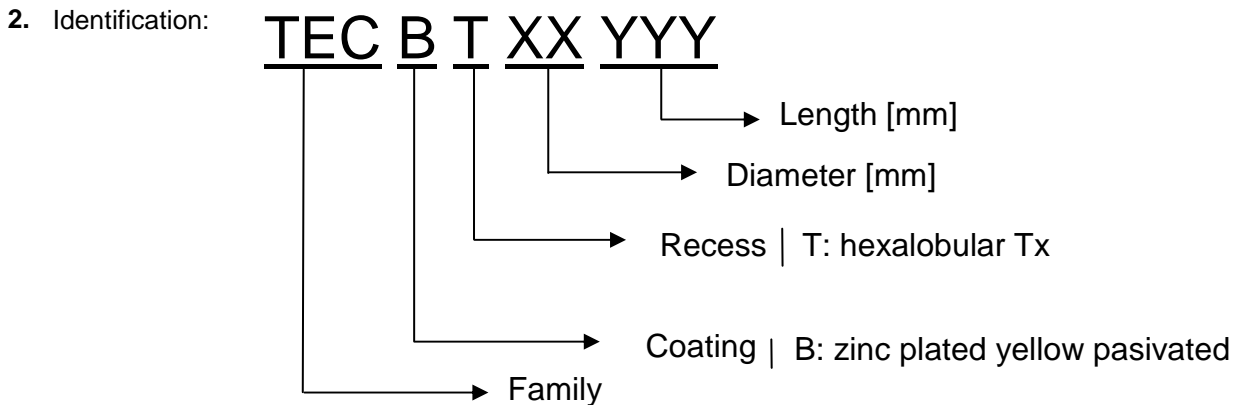

1. Product type: TEC. High performance chipboard screw washer head.



3. Intended use: Load bearing timber structures.
4. Manufacturer: Index Fixing Systems. Técnicas Expansivas S.L.  
Segador, 13  
26006 Logroño, SPAIN
5. Authorised representative: Not applicable
6. System of assessment of performance: 3
7. Harmonised standard: Notified body: Strojirenský zkušební ústav, s. p. (SZÚ). Notified body no 1015  
performed: Determination of product type  
under system: 3  
and issued: Test reports 30-11085/1, 30-11085/2 and 30-11085/3
8. European technical assessment: Not applicable
9. Declared performance:

	Essential characteristics	Performance			Harmonised technical specification	
		Units	Ø 6.0	Ø 8.0		Ø 10.0
9.1.	Characteristic yield moment $M_{y,k}$	[Nmm]	13761	35208	54731	EN 14592:2008 + A1:2012
9.2.	Characteristic withdrawal parameter $f_{ax,k}$	[N/mm <sup>2</sup> ]	11.83	8.36	11.03	EN 14592:2008 + A1:2012
		$\rho_k$ [kg/m <sup>3</sup> ]	350	350	350	
9.3.	Characteristic head pull-through parameter $f_{head,k}$	[N/mm <sup>2</sup> ]	27.12	25.11	26.25	EN 14592:2008 + A1:2012
		$\rho_k$ [kg/m <sup>3</sup> ]	350	350	350	
9.4.	Characteristic tensile capacity $f_{tens,k}$	[kN]	14.67	25.32	38.11	EN 14592:2008 + A1:2012
9.5.	Characteristic strength in torsion $f_{tor,k}$	[Nm]	13.55	31.16	54.46	EN 14592:2008 + A1:2012
9.6.	Characteristic torsional resistance into timber $R_{tor,k}$	[Nm]	3.39	9.31	11.74	EN 14592:2008 + A1:2012
		$\rho_k$ [kg/m <sup>3</sup> ]	450	450	450	
9.7.	Corrosion protection	[--]	Service class 1 according EN 1995-1-1		EN 14592:2008 + A1:2012	

**10.** The performance of the product identified in points 1 and 2 is in conformity with the declared performance in point 9

This declaration of performance is issued under the sole responsibility of the manufacturer identified in point 4.

Signed on behalf of the manufacturer by:

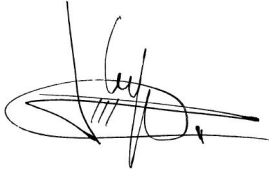
A handwritten signature in black ink, appearing to be 'Israel Jdraque', written over a horizontal line.

Israel Jdraque  
Logroño, 10.08.2017