

## MOPUR3



## CERTIFICATES



## BASE MATERIAL



## CHARACTERISTICS

- Assessed for structural applications in cracked and non-cracked concrete, M8 to M30. Rebar used as stud from  $\varnothing 8$  to  $\varnothing 32$ .
- Assessed for post-installed rebar connections  $\varnothing 8$  to  $\varnothing 32$ .
- Certificate of contact with drinking water (WRAS).
- Fire resistance certificate for post-installed rebar (CSTB).
- Pure Epoxy 3:1 red colored.
- LEED and A+ certificates.
- Use for high loads, static or quasi-static. Seismic loads C1&C2.
- Working life of 50 and/or 100 years.
- Valid for dry, wet and flooded holes.
- Valid for zinc plated steel, hot-dip galvanized, stainless steel A2, A4 and HCR.
- Service temperature range: from  $-40^{\circ}\text{C}$  to  $+70^{\circ}\text{C}$  (long term maximum temperature  $+50^{\circ}\text{C}$ ).

## VALID FOR

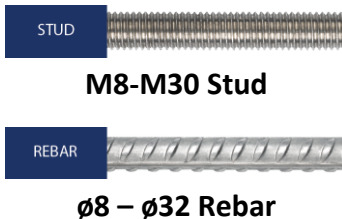

## APPLICATIONS

- Use in indoor and outdoor environments.
- Structural applications.
- Fixing of building substructures.
- Rebar and start rebar.
- For fixing enginery, balconies, awnings, shelving units, billboards, catenaries, safety barriers, railings, handrails, etc.
- Large metric sizes, retaining walls.

## DRILL HOLE CONDITION

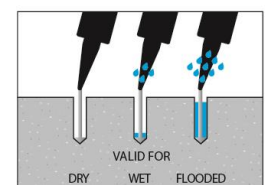

## APPLICATION EXAMPLES



## MAXIMUM RECOMMENDED LOADS [kg]

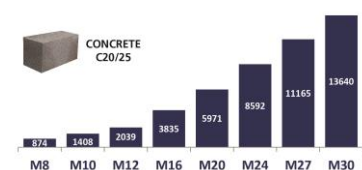

## 1. RANGE

ITEM	CODE	SIZE	PHOTO	COMPONENT	MATERIAL	
1	MOPUR30385 MOPUR30585	385 ml. 585 ml.		PURE EPOXY MORTAR	Pure epoxy resin. Format: cartridges of 385 and 585 ml.	12

## 2. ACCESORIES

ITEM	CODE	PHOTO	COMPONENT	MATERIAL
1	MOPISP3385		APPLICATION GUNS	Gun for 385 ml cartridges
	MOPISP3585			Gun for 585 ml cartridges
2	EQ-AC EQ-8.8 EQ-A2 EQ-A4		STUD BOLTS	Threaded steel stud, class 5.8 ISO 898-1 Threaded steel stud, class 8.8 ISO 898-1 Threaded stainless steel stud A2-70 Threaded stainless steel stud A4-70
3	MORCEPKIT		CLEANING BRUSHES	3 Cleaning brushes kit of $\varnothing 14$ , $\varnothing 20$ and $\varnothing 29$ mm.
4	MOBOMBA		CLEANING PUMP	Pump for cleaning dust and drill hole fragments
5	MORCAPU		MIXING NOZZLE	Plastic. Helix static mixer.

3. INSTALLATION DATA - CONCRETE FIXING (SET UP PARAMETERS)

SIZE		M8	M10	M12	M16	M20	M24	M27	M30
d <sub>0</sub> : nominal diameter	[mm]	10	12	14	18	22	26	30	35
d <sub>f</sub> : fixture hole diameter ≤	[mm]	9	12	14	18	22	26	30	33
T <sub>ins</sub> : torque ≤	[Nm]	10	20	40	80	150	200	240	275
Circular cleaning brush diameter				Ø20		Ø29		Ø40	
Assessment of seismic loads C1	[mm]	✓	✓	✓	✓	✓	✓	✓	✓
Assessment of seismic loads C2	[mm]	--	--	✓	✓	✓	--	--	--
<b>h<sub>ef,min</sub></b>									
h <sub>ef</sub> : effective depth	[mm]	60	60	70	80	90	96	108	120
h <sub>1</sub> : drill hole depth	[mm]	65	65	75	85	95	101	113	
s <sub>cr,N</sub> : critical spacing	[mm]	180	180	210	240	270	288	324	360
c <sub>cr,N</sub> : critical edge distance	[mm]	90	90	105	120	135	144	162	180
c <sub>min</sub> : minimum distance to edge	[mm]	40	40	40	40	50	50	50	50
s <sub>min</sub> : minimum spacing	[mm]	40	40	40	40	50	50	50	50
h <sub>min</sub> : minimum concrete thickness	[mm]	100	100	105	120	135	150	170	185
<b>Standard stud</b>									
h <sub>ef</sub> : effective depth	[mm]	80	90	110	128	170	210	-	280
h <sub>1</sub> : drill hole depth	[mm]	85	95	115	133	175	215	-	285
s <sub>cr,N</sub> : critical spacing	[mm]	240	270	330	384	510	630	-	840
c <sub>cr,N</sub> : critical edge distance	[mm]	120	135	165	192	255	315	-	420
c <sub>min</sub> : minimum distance to edge	[mm]	40	45	55	65	85	105	-	140
s <sub>min</sub> : minimum spacing	[mm]	40	45	55	65	85	105	-	140
h <sub>min</sub> : minimum concrete thickness	[mm]	115	125	145	165	215	263	-	345
<b>h<sub>ef,max</sub></b>									
h <sub>ef</sub> : effective depth	[mm]	160	200	240	320	400	480	540	600
h <sub>1</sub> : drill hole depth	[mm]	165	205	245	325	405	485	545	605
s <sub>cr,N</sub> : critical spacing	[mm]	480	600	720	960	1200	1440	1620	1800
c <sub>cr,N</sub> : critical edge distance	[mm]	240	300	360	480	600	720	810	900
c <sub>min</sub> : minimum distance to edge	[mm]	80	100	120	160	200	240	270	300
s <sub>min</sub> : minimum spacing	[mm]	80	100	120	160	200	240	270	300
h <sub>min</sub> : minimum concrete thickness	[mm]	195	235	275	360	445	535	600	665
5.8 / 8.8 Zinc plated stud code		EQAC08110 EQ8808110	EQAC10130 EQ8810130	EQAC12160 EQ8812160	EQAC16190 EQ8816190	EQAC20260 EQ8820260	EQAC24300 EQ8824300	---	EQAC30330 EQ8830330
A2 / A4 Stainless steel stud code		EQA208110 EQA408110	EQA210130 EQA410130	EQA212160 EQA412160	EQA216190 EQA416190	EQA220260 EQA420260	EQA224300 EQA424300	---	EQA230330 EQA430330

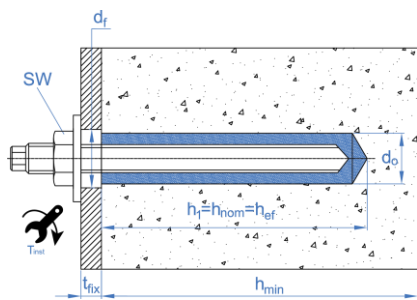

- The  $h_{ef}$  depth value may be selected by the user ranging between  $h_{ef,min} = 8d$  and  $h_{ef,max} = 20d$ . Any intermediate values may be interpolated.
- Critical distances are those where anchors in a group of anchors are not influenced by one another with regard to tension load effects. For smaller distances, down to minimum distances, corresponding reduction coefficients must be applied.
- Standard studs are available for each measurement, as shown in the table.

## 4. PRODUCT SET UP

### 4.1. CONCRETE SET UP

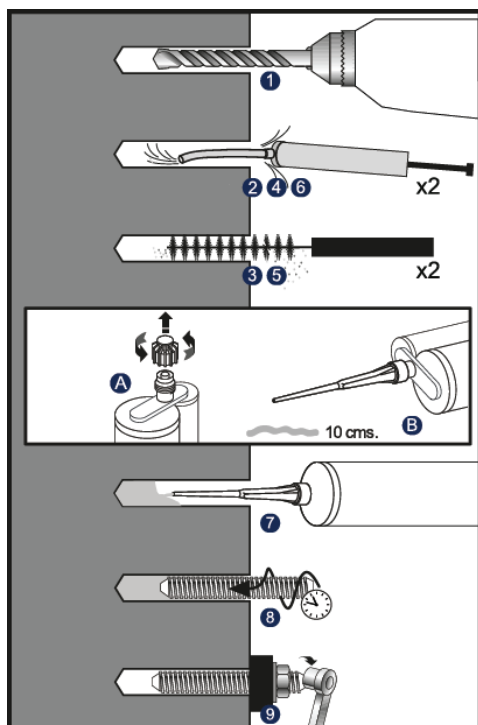

#### 1. DRILL

Check the concrete base is compact and porosity is insignificant.  
 Suitable for wet, dry or flooded drill holes.  
 Cartridge installation temperature:  $\geq 5\text{ }^{\circ}\text{C}$ .  
 Base material installation temperature: MOPUR3  $\geq +5\text{ }^{\circ}\text{C}$   
 Use drill in hammer mode.  
 Drill to the specified diameter and depth values

#### 2 - 6. BLOW AND CLEAN

Clear the drill holes completely of dust and fragments by following the procedure shown in the picture. If the drill hole is flooded, the water must be removed before mortar is injected.

#### A - B. OPEN CARTRIDGE

Screw the nozzle into the cartridge and place the assembly in the application gun. Squeeze on the trigger repeatedly until the mortar comes out of the nozzle in a uniform red color. Any iridescence indicates improper mixing. Always discard the first two doses of each cartridge: these are never to be used for fixing.

#### 7. INJECT MORTAR

Insert the nozzle to the bottom of the drill hole and apply mortar: gradually remove the nozzle, ensuring there are no air bubbles. Fill the hole to  $\frac{1}{2}$  and  $\frac{3}{4}$  of its depth.  
 In the event of not fully using the cartridge, leave nozzle attached. Only change if using again and handling time has expired, remembering to discard the first two doses of mortar.

#### 8. INSTALLATION

Introduce the stud to be installed by screwing it lightly down to the installation depth value manually; ensuring the mortar covers the stud thread. The introduction of the anchor must take place within the handling time. The mortar must seep from the top of the drill hole to ensure it is completely full and there are no gaps between the stud and the drill hole.

### TEMPERATURE AND CURING TIME

TYPE	Base material temperature [°C]	Handling time [min]	Curing time [hrs]
MOPUR3	+5	300	24
	+5 a +10	150	
	+10 a +15	40	18

	+15 a +20	25	12
	+20 a +25	18	8
	+25 a +30	12	6
	+30 a +35	8	4
	+35 a +40	6	2

## 9. APPLY TORQUE

Once the curing time has elapsed, apply torque, never exceeding the values indicated in the table.

## 5. STORAGE CONDITIONS

Keep the product stored in a cool, dry place, away from direct sunlight and heat sources, at an average temperature between +5 °C and +25 °C.



Shelf life of unopened cartridge: 18 months from the date of manufacture. The expiration date is indicated on the cartridge.

## 6. RESISTANCES

### 6.1 CONCRETE FIXATION

Characteristic resistances for C20/25 concrete for an isolated anchor (without considering anchor-to-anchor or anchor-to-edge distance effects), for static or quasi-static loads and class 5.8,8.8 studs or A2-70 and A4-70 stainless steel are shown in tables below.

#### CHARACTERISTIC RESISTANCES

CONCRETE CLASS	SIZE				M8	M10	M12	M16	M20	M24	M27	M30		
NON-CRACKED CONCRETE	ZINC PLATED	Tension	$h_{ef,min} = 8d - 5.8$	$N_{Rk}$	[kN]	<u>18,0</u>	<b>22,9</b>	<b>28,8</b>	<b>35,2</b>	<b>42,0</b>	<b>46,3</b>	<b>55,2</b>	<b>64,7</b>	
			$h_{ef,min} = 8d - 8.8$	$N_{Rk}$	[kN]	21,1	<b>22,9</b>	<b>28,8</b>	<b>35,2</b>	<b>42,0</b>	<b>46,3</b>	<b>55,2</b>	<b>64,7</b>	
			Standard stud 5.8	$N_{Rk}$	[kN]	<u>18,0</u>	<u>29,0</u>	<u>42,0</u>	<b>71,2</b>	<b>109,0</b>	<b>149,7</b>	---	<b>230,5</b>	
			Standard stud85.8	$N_{Rk}$	[kN]	28,1	36,8	53,9	<b>71,2</b>	<b>109,0</b>	<b>149,7</b>	---	<b>230,5</b>	
			$h_{ef,max} = 20d - 5.8$	$N_{Rk}$	[kN]	<u>18,0</u>	<u>29,0</u>	<u>42,0</u>	<u>79,0</u>	<u>123,0</u>	<u>177,0</u>	<u>230,0</u>	<u>281,0</u>	
			$h_{ef,max} = 20d - 8.8$	$N_{Rk}$	[kN]	<u>29,0</u>	<u>46,0</u>	<u>67,0</u>	<u>126,0</u>	<u>196,0</u>	<u>282,0</u>	<u>367,0</u>	<u>449,0</u>	
		Shear	$h_{ef,min} = 8d - 5.8$	$V_{Rk}$	[kN]	<u>9,0</u>	<u>15,0</u>	<u>21,0</u>	<u>39,0</u>	<u>61,0</u>	<b>92,5</b>	<b>110,4</b>	<b>129,3</b>	
			$h_{ef,min} = 8d - 8.8$	$V_{Rk}$	[kN]	<u>15,0</u>	<u>23,0</u>	<u>34,0</u>	<b>70,4</b>	<b>84,0</b>	<b>92,5</b>	<b>110,4</b>	<b>129,3</b>	
			Standard stud 5.8	$V_{Rk}$	[kN]	<u>9,0</u>	<u>15,0</u>	<u>21,0</u>	<u>39,0</u>	<u>61,0</u>	<u>88,0</u>	<u>115,0</u>	<u>140,0</u>	
			Standard stud85.8	$V_{Rk}$	[kN]	<u>15,0</u>	<u>23,0</u>	<u>34,0</u>	<u>63,0</u>	<u>98,0</u>	<u>141,0</u>	<u>184,0</u>	<u>224,0</u>	
			$h_{ef,max} = 20d - 5.8$	$V_{Rk}$	[kN]	<u>9,0</u>	<u>15,0</u>	<u>21,0</u>	<u>39,0</u>	<u>61,0</u>	<u>88,0</u>	<u>115,0</u>	<u>140,0</u>	
			$h_{ef,max} = 20d - 8.8$	$V_{Rk}$	[kN]	<u>15,0</u>	<u>23,0</u>	<u>34,0</u>	<u>63,0</u>	<u>98,0</u>	<u>141,0</u>	<u>184,0</u>	<u>224,0</u>	
	STAINLESS STEEL	Tension	$h_{ef,min} = 8d$	$N_{Rk}$	[kN]	<u>26,0</u>	<b>22,9</b>	<b>28,8</b>	<b>35,2</b>	<b>42,0</b>	<b>46,3</b>	<b>55,2</b>	<b>64,7</b>	
			Standard stud	$N_{Rk}$	[kN]	<u>26,0</u>	<u>41,0</u>	<u>59,0</u>	<b>71,2</b>	<b>109,0</b>	<b>149,7</b>	---	<b>230,5</b>	
			$h_{ef,max} = 20d$	$N_{Rk}$	[kN]	<u>26,0</u>	<u>41,0</u>	<u>59,0</u>	<u>110,0</u>	<u>172,0</u>	<u>247,0</u>	<u>321,0</u>	<u>393,0</u>	
		Shear	$h_{ef,min} = 8d$	$V_{Rk}$	[kN]	<u>13,0</u>	<u>20,0</u>	<u>30,0</u>	<u>55,0</u>	<u>86,0</u>	<b>92,5</b>	<b>110,4</b>	<b>129,3</b>	
			Standard stud	$V_{Rk}$	[kN]	<u>13,0</u>	<u>20,0</u>	<u>30,0</u>	<u>55,0</u>	<u>86,0</u>	<u>124,0</u>	<u>161,0</u>	<u>196,0</u>	
			$h_{ef,max} = 20d$	$V_{Rk}$	[kN]	<u>13,0</u>	<u>20,0</u>	<u>30,0</u>	<u>55,0</u>	<u>86,0</u>	<u>124,0</u>	<u>161,0</u>	<u>196,0</u>	
	CRACKED CONCRETE	ZINC PLATED	Tension	$h_{ef,min} = 8d - 5.8$	$N_{Rk}$	[kN]	12,0	15,0	19,7	<b>24,6</b>	<b>29,4</b>	<b>32,3</b>	<b>38,6</b>	<b>45,2</b>
				$h_{ef,min} = 8d - 8.8$	$N_{Rk}$	[kN]	12,0	15,0	19,7	<b>24,6</b>	<b>29,4</b>	<b>32,3</b>	<b>38,6</b>	<b>45,2</b>
				Standard stud 5.8	$N_{Rk}$	[kN]	16,0	22,6	31,1	48,2	74,7	<b>104,7</b>	--	131,9
				Standard stud85.8	$N_{Rk}$	[kN]	16,0	22,6	31,1	48,2	74,7	<b>104,7</b>	--	131,9
				$h_{ef,max} = 20d - 5.8$	$N_{Rk}$	[kN]	<u>18,0</u>	<u>29,0</u>	<u>42,0</u>	<u>79,0</u>	<u>123,0</u>	<u>177,0</u>	229,0	<u>281,0</u>
				$h_{ef,max} = 20d - 8.8$	$N_{Rk}$	[kN]	<u>29,0</u>	<u>46,0</u>	<u>67,0</u>	120,6	175,9	253,3	229,0	282,7
Shear			$h_{ef,min} = 8d - 5.8$	$V_{Rk}$	[kN]	<u>9,0</u>	<u>15,0</u>	<u>21,0</u>	<u>39,0</u>	<b>58,8</b>	<b>64,7</b>	<b>77,3</b>	<b>90,5</b>	
			$h_{ef,min} = 8d - 8.8$	$V_{Rk}$	[kN]	<u>15,0</u>	<u>23,0</u>	<u>40,3</u>	<b>49,2</b>	<b>58,8</b>	<b>64,7</b>	<b>77,3</b>	<b>90,5</b>	
			Standard stud 5.8	$V_{Rk}$	[kN]	<u>9,0</u>	<u>15,0</u>	<u>21,0</u>	<u>39,0</u>	<u>61,0</u>	<u>88,0</u>	<u>115,0</u>	<u>140,0</u>	
			Standard stud85.8	$V_{Rk}$	[kN]	<u>15,0</u>	<u>23,0</u>	<u>34,0</u>	<u>63,0</u>	<u>98,0</u>	<u>141,0</u>	<u>184,0</u>	<u>224,0</u>	
			$h_{ef,max} = 20d - 5.8$	$V_{Rk}$	[kN]	<u>9,0</u>	<u>15,0</u>	<u>21,0</u>	<u>39,0</u>	<u>61,0</u>	<u>88,0</u>	<u>115,0</u>	<u>140,0</u>	
			$h_{ef,max} = 20d - 8.8$	$V_{Rk}$	[kN]	<u>15,0</u>	<u>23,0</u>	<u>34,0</u>	<u>63,0</u>	<u>98,0</u>	<u>141,0</u>	<u>184,0</u>	<u>224,0</u>	
STAINLESS STEEL		Tension	$h_{ef,min} = 8d$	$N_{Rk}$	[kN]	12,0	15,0	19,7	<b>24,6</b>	<b>29,4</b>	<b>32,3</b>	<b>38,6</b>	<b>45,2</b>	
			Standard stud	$N_{Rk}$	[kN]	16,0	22,6	31,1	48,2	74,7	<b>104,7</b>	--	131,9	
			$h_{ef,max} = 20d$	$N_{Rk}$	[kN]	<u>26,0</u>	<u>41,0</u>	<u>59,0</u>	<u>110,0</u>	<u>172,0</u>	<u>247,0</u>	229,0	282,7	
		Shear	$h_{ef,min} = 8d$	$V_{Rk}$	[kN]	<u>13,0</u>	<u>20,0</u>	<u>30,0</u>	<b>49,2</b>	<b>58,8</b>	<b>64,7</b>	<b>77,3</b>	<b>90,5</b>	
			Standard stud	$V_{Rk}$	[kN]	<u>13,0</u>	<u>20,0</u>	<u>30,0</u>	<u>55,0</u>	<u>86,0</u>	<u>124,0</u>	<u>161,0</u>	<u>196,0</u>	
			$h_{ef,max} = 20d$	$V_{Rk}$	[kN]	<u>13,0</u>	<u>20,0</u>	<u>30,0</u>	<u>55,0</u>	<u>86,0</u>	<u>124,0</u>	<u>161,0</u>	<u>196,0</u>	

## DESIGN RESISTANCES

CONCRETE CLASS	SIZE				M8	M10	M12	M16	M20	M24	M27	M30		
NON-CRACKED CONCRETE	ZINC PLATED	Tension	$h_{ef,min} = 8d - 5.8$	$N_{Rd}$	[kN]	<u>12,0</u>	<b>15,2</b>	<b>19,2</b>	<b>23,4</b>	<b>28,0</b>	<b>30,8</b>	<b>36,8</b>	<b>43,1</b>	
			$h_{ef,min} = 8d - 8.8$	$N_{Rd}$	[kN]	14,0	<b>15,2</b>	<b>19,2</b>	<b>23,4</b>	<b>28,0</b>	<b>30,8</b>	<b>36,8</b>	<b>43,1</b>	
			Standard stud 5.8	$N_{Rd}$	[kN]	<u>12,0</u>	<u>19,3</u>	<u>28,0</u>	<b>47,4</b>	<b>72,6</b>	<b>99,8</b>	---	<b>153,6</b>	
			Standard stud85.8	$N_{Rd}$	[kN]	18,7	24,5	35,9	<b>47,4</b>	<b>72,6</b>	<b>99,8</b>	---	<b>153,6</b>	
			$h_{ef,max} = 20d - 5.8$	$N_{Rd}$	[kN]	<u>12,0</u>	<u>19,3</u>	<u>28,0</u>	<u>52,6</u>	<u>82,0</u>	<u>118,0</u>	<u>153,3</u>	<u>187,3</u>	
			$h_{ef,max} = 20d - 8.8$	$N_{Rd}$	[kN]	<u>19,3</u>	<u>30,6</u>	<u>44,6</u>	<u>84,0</u>	<u>130,6</u>	<u>188,0</u>	<u>244,6</u>	<u>299,3</u>	
		Shear	$h_{ef,min} = 8d - 5.8$	$V_{Rd}$	[kN]	<u>7,2</u>	<u>12,0</u>	<u>16,8</u>	<u>31,2</u>	<u>48,8</u>	<b>61,7</b>	<b>73,6</b>	<b>86,2</b>	
			$h_{ef,min} = 8d - 8.8$	$V_{Rd}$	[kN]	<u>12,0</u>	<u>18,4</u>	<u>27,2</u>	<b>46,9</b>	<b>56,0</b>	<b>61,7</b>	<b>73,6</b>	<b>86,2</b>	
			Standard stud 5.8	$V_{Rd}$	[kN]	<u>7,2</u>	<u>12,0</u>	<u>16,8</u>	<u>31,2</u>	<u>48,8</u>	<u>70,4</u>	<u>92,0</u>	<u>112,0</u>	
			Standard stud85.8	$V_{Rd}$	[kN]	<u>12,0</u>	<u>18,4</u>	<u>27,2</u>	<u>50,4</u>	<u>78,4</u>	<u>112,8</u>	<u>147,2</u>	<u>179,2</u>	
			$h_{ef,max} = 20d - 5.8$	$V_{Rd}$	[kN]	<u>7,2</u>	<u>12,0</u>	<u>16,8</u>	<u>31,2</u>	<u>48,8</u>	<u>70,4</u>	<u>92,0</u>	<u>112,0</u>	
			$h_{ef,max} = 20d - 8.8$	$V_{Rd}$	[kN]	<u>12,0</u>	<u>18,4</u>	<u>27,2</u>	<u>50,4</u>	<u>78,4</u>	<u>112,8</u>	<u>147,2</u>	<u>179,2</u>	
	STAINLESS STEEL	Tension	$h_{ef,min} = 8d$	$N_{Rd}$	[kN]	<u>13,9</u>	<b>15,2</b>	<b>19,2</b>	<b>23,4</b>	<b>28,0</b>	<b>30,8</b>	<b>36,8</b>	<b>43,1</b>	
			Standard stud	$N_{Rd}$	[kN]	<u>13,9</u>	<u>21,9</u>	<u>31,5</u>	<b>47,4</b>	<b>72,6</b>	<b>99,8</b>	---	<b>153,6</b>	
			$h_{ef,max} = 20d$	$N_{Rd}$	[kN]	<u>13,9</u>	<u>21,9</u>	<u>31,5</u>	<u>58,8</u>	<u>91,9</u>	<u>132,0</u>	<u>171,6</u>	<u>210,1</u>	
		Shear	$h_{ef,min} = 8d$	$V_{Rd}$	[kN]	<u>8,3</u>	<u>12,8</u>	<u>19,2</u>	<u>35,2</u>	<u>55,1</u>	<b>61,7</b>	<b>73,6</b>	<b>86,2</b>	
			Standard stud	$V_{Rd}$	[kN]	<u>8,3</u>	<u>12,8</u>	<u>19,2</u>	<u>35,2</u>	<u>55,1</u>	<u>79,4</u>	<u>103,2</u>	<u>125,6</u>	
			$h_{ef,max} = 20d$	$V_{Rd}$	[kN]	<u>8,3</u>	<u>12,8</u>	<u>19,2</u>	<u>35,2</u>	<u>55,1</u>	<u>79,4</u>	<u>103,2</u>	<u>125,6</u>	
	60, 3, CRACKED CONCRETE	ZINC PLATED	Tension	$h_{ef,min} = 8d - 5.8$	$N_{Rd}$	[kN]	8,0	10,0	13,1	<b>16,4</b>	<b>19,6</b>	<b>21,5</b>	<b>25,7</b>	<b>30,1</b>
				$h_{ef,min} = 8d - 8.8$	$N_{Rd}$	[kN]	8,0	10,0	13,1	<b>16,4</b>	<b>19,6</b>	<b>21,5</b>	<b>25,7</b>	<b>30,1</b>
				Standard stud 5.8	$N_{Rd}$	[kN]	10,7	15,0	20,7	32,1	49,8	<b>69,8</b>	--	87,9
				Standard stud85.8	$N_{Rd}$	[kN]	10,7	15,0	20,7	32,1	49,8	<b>69,8</b>	--	87,9
				$h_{ef,max} = 20d - 5.8$	$N_{Rd}$	[kN]	<u>12,0</u>	<u>19,3</u>	<u>28,0</u>	<u>52,6</u>	<u>82,0</u>	<u>118,0</u>	152,6	<u>187,3</u>
				$h_{ef,max} = 20d - 8.8$	$N_{Rd}$	[kN]	<u>19,3</u>	<u>30,6</u>	<u>44,6</u>	80,4	117,2	168,8	152,6	188,5
Shear			$h_{ef,min} = 8d - 5.8$	$V_{Rd}$	[kN]	<u>7,2</u>	<u>12,0</u>	<u>16,8</u>	<u>31,2</u>	<b>39,2</b>	<b>43,1</b>	<b>51,5</b>	<b>60,3</b>	
			$h_{ef,min} = 8d - 8.8$	$V_{Rd}$	[kN]	<u>12,0</u>	<u>18,4</u>	<u>26,8</u>	<b>32,8</b>	<b>39,2</b>	<b>43,1</b>	<b>51,5</b>	<b>60,3</b>	
			Standard stud 5.8	$V_{Rd}$	[kN]	<u>7,2</u>	<u>12,0</u>	<u>16,8</u>	<u>31,2</u>	<u>48,8</u>	<u>70,4</u>	<u>92,0</u>	<u>112,0</u>	
			Standard stud85.8	$V_{Rd}$	[kN]	<u>12,0</u>	<u>18,4</u>	<u>27,2</u>	<u>50,4</u>	<u>78,4</u>	<u>112,8</u>	<u>147,2</u>	<u>179,2</u>	
			$h_{ef,max} = 20d - 5.8$	$V_{Rd}$	[kN]	<u>7,2</u>	<u>12,0</u>	<u>16,8</u>	<u>31,2</u>	<u>48,8</u>	<u>70,4</u>	<u>92,0</u>	<u>112,0</u>	
			$h_{ef,max} = 20d - 8.8$	$V_{Rd}$	[kN]	<u>12,0</u>	<u>18,4</u>	<u>27,2</u>	<u>50,4</u>	<u>78,4</u>	<u>112,8</u>	<u>147,2</u>	<u>179,2</u>	
STAINLESS STEEL		Tension	$h_{ef,min} = 8d$	$N_{Rd}$	[kN]	8,0	10,0	13,1	<b>16,4</b>	<b>19,6</b>	<b>21,5</b>	<b>25,7</b>	<b>30,1</b>	
			Standard stud	$N_{Rd}$	[kN]	10,7	15,0	20,7	32,1	49,8	<b>69,8</b>	--	87,9	
			$h_{ef,max} = 20d$	$N_{Rd}$	[kN]	<u>13,9</u>	<u>21,9</u>	<u>31,5</u>	<u>58,8</u>	<u>91,9</u>	<u>132,0</u>	152,6	188,5	
		Shear	$h_{ef,min} = 8d$	$V_{Rd}$	[kN]	<u>8,3</u>	<u>12,8</u>	<u>19,2</u>	<b>32,8</b>	<b>39,2</b>	<b>43,1</b>	<b>51,5</b>	<b>60,3</b>	
			Standard stud	$V_{Rd}$	[kN]	<u>8,3</u>	<u>12,8</u>	<u>19,2</u>	<u>35,2</u>	<u>55,1</u>	<u>79,4</u>	<u>103,2</u>	<u>125,6</u>	
			$h_{ef,max} = 20d$	$V_{Rd}$	[kN]	<u>8,3</u>	<u>12,8</u>	<u>19,2</u>	<u>35,2</u>	<u>55,1</u>	<u>79,4</u>	<u>103,2</u>	<u>125,6</u>	

**MAXIMUM LOADS RECOMMENDED (when  $\gamma_F = 1.4$ )**

CONCRETE CLASS	SIZE				M8	M10	M12	M16	M20	M24	M27	M30		
NON-CRACKED CONCRETE	ZINC PLATED	Tension	$h_{ef,min} = 8d - 5.8$	$N_{rec}$	[kN]	<u>8,5</u>	<b>10,8</b>	<b>13,7</b>	<b>16,7</b>	<b>20,0</b>	<b>22,0</b>	<b>26,2</b>	<b>30,7</b>	
			$h_{ef,min} = 8d - 8.8$	$N_{rec}$	[kN]	10,0	<b>10,8</b>	<b>13,7</b>	<b>16,7</b>	<b>20,0</b>	<b>22,0</b>	<b>26,2</b>	<b>30,7</b>	
			Standard stud 5.8	$N_{rec}$	[kN]	<u>8,5</u>	<u>13,8</u>	<u>20,0</u>	<b>33,9</b>	<b>51,9</b>	<b>71,2</b>	---	<b>109,7</b>	
			Standard stud85.8	$N_{rec}$	[kN]	13,4	17,5	25,6	<b>33,9</b>	<b>51,9</b>	<b>71,2</b>	---	<b>109,7</b>	
			$h_{ef,max} = 20d - 5.8$	$N_{rec}$	[kN]	<u>8,5</u>	<u>13,8</u>	<u>20,0</u>	<u>37,6</u>	<u>58,5</u>	<u>84,2</u>	<u>109,5</u>	<u>133,8</u>	
			$h_{ef,max} = 20d - 8.8$	$N_{rec}$	[kN]	<u>13,8</u>	<u>21,9</u>	<u>31,9</u>	<u>60,0</u>	<u>93,3</u>	<u>134,2</u>	<u>174,7</u>	<u>213,8</u>	
		Shear	$h_{ef,min} = 8d - 5.8$	$V_{rec}$	[kN]	<u>5,1</u>	<u>8,5</u>	<u>12,0</u>	<u>22,2</u>	<u>34,8</u>	<b>44,0</b>	<b>52,5</b>	<b>61,5</b>	
			$h_{ef,min} = 8d - 8.8$	$V_{rec}$	[kN]	<u>8,5</u>	<u>13,1</u>	<u>19,4</u>	<b>33,5</b>	<b>40,0</b>	<b>44,0</b>	<b>52,5</b>	<b>61,5</b>	
			Standard stud 5.8	$V_{rec}$	[kN]	<u>5,1</u>	<u>8,5</u>	<u>12,0</u>	<u>22,2</u>	<u>34,8</u>	<u>50,2</u>	<u>65,7</u>	<u>80,0</u>	
			Standard stud85.8	$V_{rec}$	[kN]	<u>8,5</u>	<u>13,1</u>	<u>19,4</u>	<u>36,0</u>	<u>56,0</u>	<u>80,5</u>	<u>105,1</u>	<u>128,0</u>	
			$h_{ef,max} = 20d - 5.8$	$V_{rec}$	[kN]	<u>5,1</u>	<u>8,5</u>	<u>12,0</u>	<u>22,2</u>	<u>34,8</u>	<u>50,2</u>	<u>65,7</u>	<u>80,0</u>	
			$h_{ef,max} = 20d - 8.8$	$V_{rec}$	[kN]	<u>8,5</u>	<u>13,1</u>	<u>19,4</u>	<u>36,0</u>	<u>56,0</u>	<u>80,5</u>	<u>105,1</u>	<u>128,0</u>	
	STAINLESS STEEL	Tension	$h_{ef,min} = 8d$	$N_{rec}$	[kN]	<u>9,9</u>	<b>10,8</b>	<b>13,7</b>	<b>16,7</b>	<b>20,0</b>	<b>22,0</b>	<b>26,2</b>	<b>30,7</b>	
			Standard stud	$N_{rec}$	[kN]	<u>9,9</u>	<u>15,6</u>	<u>22,5</u>	<b>33,9</b>	<b>51,9</b>	<b>71,2</b>	---	<b>109,7</b>	
			$h_{ef,max} = 20d$	$N_{rec}$	[kN]	<u>9,9</u>	<u>15,6</u>	<u>22,5</u>	<u>42,0</u>	<u>65,7</u>	<u>94,3</u>	<u>122,6</u>	<u>150,1</u>	
		Shear	$h_{ef,min} = 8d$	$V_{rec}$	[kN]	<u>5,9</u>	<u>9,1</u>	<u>13,7</u>	<u>25,1</u>	<u>39,3</u>	<b>44,0</b>	<b>52,5</b>	<b>61,5</b>	
			Standard stud	$V_{rec}$	[kN]	<u>5,9</u>	<u>9,1</u>	<u>13,7</u>	<u>25,1</u>	<u>39,3</u>	<u>56,7</u>	<u>73,7</u>	<u>89,7</u>	
			$h_{ef,max} = 20d$	$V_{rec}$	[kN]	<u>5,9</u>	<u>9,1</u>	<u>13,7</u>	<u>25,1</u>	<u>39,3</u>	<u>56,7</u>	<u>73,7</u>	<u>89,7</u>	
	CRACKED CONCRETE	ZINC PLATED	Tension	$h_{ef,min} = 8d - 5.8$	$N_{rec}$	[kN]	5,7	7,1	9,4	<b>11,7</b>	<b>14,0</b>	<b>15,4</b>	<b>18,4</b>	<b>21,5</b>
				$h_{ef,min} = 8d - 8.8$	$N_{rec}$	[kN]	5,7	7,1	9,4	<b>11,7</b>	<b>14,0</b>	<b>15,4</b>	<b>18,4</b>	<b>21,5</b>
				Standard stud 5.8	$N_{rec}$	[kN]	7,6	10,7	14,8	22,9	35,6	<b>49,9</b>	--	62,8
				Standard stud85.8	$N_{rec}$	[kN]	7,6	10,7	14,8	22,9	35,6	<b>49,9</b>	--	62,8
				$h_{ef,max} = 20d - 5.8$	$N_{rec}$	[kN]	<u>8,5</u>	<u>13,8</u>	<u>20,0</u>	<u>37,6</u>	<u>58,5</u>	<u>84,2</u>	109,0	<u>133,8</u>
				$h_{ef,max} = 20d - 8.8$	$N_{rec}$	[kN]	<u>13,8</u>	<u>21,9</u>	<u>31,9</u>	57,4	83,7	120,6	109,0	134,6
Shear			$h_{ef,min} = 8d - 5.8$	$V_{rec}$	[kN]	<u>5,1</u>	<u>8,5</u>	<u>12,0</u>	<u>22,2</u>	<b>28,0</b>	<b>30,8</b>	<b>36,8</b>	<b>43,1</b>	
			$h_{ef,min} = 8d - 8.8$	$V_{rec}$	[kN]	<u>8,5</u>	<u>13,1</u>	<u>19,2</u>	<b>23,4</b>	<b>28,0</b>	<b>30,8</b>	<b>36,8</b>	<b>43,1</b>	
			Standard stud 5.8	$V_{rec}$	[kN]	<u>5,1</u>	<u>8,5</u>	<u>12,0</u>	<u>22,2</u>	<u>34,8</u>	<u>50,2</u>	<u>65,7</u>	<u>80,0</u>	
			Standard stud85.8	$V_{rec}$	[kN]	<u>8,5</u>	<u>13,1</u>	<u>19,4</u>	<u>36,0</u>	<u>56,0</u>	<u>80,5</u>	<u>105,1</u>	<u>128,0</u>	
			$h_{ef,max} = 20d - 5.8$	$V_{rec}$	[kN]	<u>5,1</u>	<u>8,5</u>	<u>12,0</u>	<u>22,2</u>	<u>34,8</u>	<u>50,2</u>	<u>65,7</u>	<u>80,0</u>	
			$h_{ef,max} = 20d - 8.8$	$V_{rec}$	[kN]	<u>8,5</u>	<u>13,1</u>	<u>19,4</u>	<u>36,0</u>	<u>56,0</u>	<u>80,5</u>	<u>105,1</u>	<u>128,0</u>	
STAINLESS STEEL		Tension	$h_{ef,min} = 8d$	$N_{rec}$	[kN]	5,7	7,1	9,4	<b>11,7</b>	<b>14,0</b>	<b>15,4</b>	<b>18,4</b>	<b>21,5</b>	
			Standard stud	$N_{rec}$	[kN]	7,6	10,7	14,8	22,9	35,6	<b>49,9</b>	--	62,8	
			$h_{ef,max} = 20d$	$N_{rec}$	[kN]	<u>9,9</u>	<u>15,6</u>	<u>22,5</u>	<u>42,0</u>	<u>65,7</u>	<u>94,3</u>	109,0	134,6	
		Shear	$h_{ef,min} = 8d$	$V_{rec}$	[kN]	<u>5,9</u>	<u>9,1</u>	<u>13,7</u>	<b>23,5</b>	<b>28,0</b>	<b>30,8</b>	<b>36,8</b>	<b>43,1</b>	
			Standard stud	$V_{rec}$	[kN]	<u>5,9</u>	<u>9,1</u>	<u>13,7</u>	<u>25,1</u>	<u>39,3</u>	<u>56,7</u>	<u>73,7</u>	<u>89,7</u>	
			$h_{ef,max} = 20d$	$V_{rec}$	[kN]	<u>5,9</u>	<u>9,1</u>	<u>13,7</u>	<u>25,1</u>	<u>39,3</u>	<u>56,7</u>	<u>73,7</u>	<u>89,7</u>	

1 KN ≈ 100 kg

The italic font underlined values indicate steel failure, the bold values indicate concrete failure and the rest indicates pull-out failure.

**COEFFICIENTS FOR TENSION LOADS  
IN PULL-OUT FAILURE IN HIGH-RESISTANCE CONCRETE TYPES**

CONCRETE COEFFICIENT	C25/30	C30/37	C35/45	C40/50	C45/55	C50/60
$\Psi_c$ (Non-cracked)	1,02	1,04	1,06	1,07	1,08	1,09
$\Psi_c$ (Cracked)						

## 7. OFFICIAL DOCUMENTATION

The following documents are available through our Sales Department or on our official website: [www.indexfix.com](http://www.indexfix.com):

- MOPUR3 Safety Data Sheet.
- European Technical Assessment ETA 17/0659 for use in cracked and non-cracked concrete according to EAD 330232-00-0601, option 1, for M8 to M30.
- European Technical Approval ETA 17/0658 for the installation of post-installed rebar with diameters from 8 to 32 mm according to technical report EAD 330087-01-0601.
- Classified A+ according to French Regulation DEVL11044875A relative to the emission of volatile pollutants for indoor use.
- LEED MOPUR3 Certification of sustainability
- WRAS certificate - 1506532 of material admitted for use in contact with drinking water.
- CSTB certificate (MRF 26072903 \_ SP0363-1) of 14/12/2017 of the material's behavior in contact with fire for post-installed rebar connections.
- Declaration of Performance DoP MOPUR3.
- INDEXcal anchor calculation software.
- INDEXmor cartridge calculation needs software.