



AB-GA



AB-GM



AB-GS



AB-IP



AB-TO



AB-GD



AB-SI

CHARACTERISTICS

- Heavy-duty clamps for heavyweight pipes.
- Variety of formats: isophonic or standard.
- Coating solutions for every scenario: galvanized, zinc-plated, yellow painted.
- U bolt and support, installation flexibility.
- Yellow gas pipe clamp for quick detection of gas pipes.
- Double thread clamps M8+M10.
- FM certificate for firefighting pipes.
- Uses: sanitation, electric installations, ventilation, air conditioning, gas pipes, firefighting, etc.

BASE MATERIAL

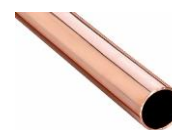

1. RANGE

ITEM	CODE	PHOTO	SIZES [mm]	COATING	MAXIMUM LOAD RECOMMENDED [kg]	THICKNESS [mm]	WIDTH [mm]	COUPLING NUT	CERTIFICATION	APPLICATIONS	ISOPHONIC	TBC
1	AB-GA		Ø18 – Ø160		150 – 200	1,8 – 2,3	19	M8 ≤ Ø54 M8+M10 > Ø54	According to UNE-EN ISO 4892 	Gas	-	-
2	AB-GS		Ø10 + Ø54		70 - 100	1,2	11 – 14	M6	Fast Lateral According to UNE-EN ISO 4892 	Gas	-	-
3	AB-GD		Ø12 + Ø28		70	0,8 – 1,5	12	M6	According to UNE-EN ISO 4892 	Gas	-	-
4	AB-GM		Ø12 + Ø35		70	1,2	11 – 12	M6	Fast Lateral According to UNE-EN ISO 4892 	Gas	-	-
5	AB-IP		---		--	1,5	19	-	-	HSW and CW Gas Sanitary Heating Air Conditioning Electrical	✓	✓
6	AB-SI		3 holes/ 25 holes		--	3	20	-	-	HSW and CW Gas Sanitary Heating Air Conditioning Electrical	✓	✓
7	AB-TO		M6 x 15		--	--	--	-	-	HSW and CW Gas Sanitary Heating Air Conditioning Electrical	-	-

2. INSTALLATION DATA

2.1 AB-GA

Yellow gas pipe clamp M8+M10



Benefits



Coating



Yellow painted

Base Material



Steel pipe

Gas pipe

PVC pipe

Installation Data

Code	Size [mm]	Ø D (mm)	Ø D (")	A x B (mm)	Maximum load recommended (kg)	M	Characteristics
ABGA018	18	16 – 20	3/8"	19x1.8	200	M8	<ul style="list-style-type: none"> • Pipes from Ø18 to Ø160 mm. • Surface coating: yellow painted for quick detection of gas pipes. • Steel profile of 1.8+2.3 mm thickness. • Side screws with plastic washer to avoid losses. • Welded Nut: <ul style="list-style-type: none"> ○ Only M8: from Ø18 to Ø54. ○ M8+M10: from Ø60 to Ø160. • Recommended for gas pipes • According to UNE-EN ISO 4892
ABGA022	22	20 – 24	1/2"	19x1.8	200	M8	
ABGA028	28	26 – 30	3/4"	19x1.8	200	M8	
ABGA035	35	33 – 37	1"	19x1.8	200	M8	
ABGA040	40	38 – 42	1 1/4"	19x1.8	200	M8	
ABGA048	48	46 – 50	1 1/2"	19x1.8	200	M8	
ABGA054	54	52 – 56	-	19x1.8	200	M8	
ABGA060	60	58 – 62	2"	19x1.8	200	M8+M10	
ABGA075	75	73 – 77	2 1/2"	19x1.8	200	M8+M10	
ABGA090	90	88 – 92	3"	19x1.8	200	M8+M10	
ABGA100	100	98 – 102	3 1/2"	19x1.8	200	M8+M10	
ABGA110	110	108 – 112	-	19x1.8	200	M8+M10	
ABGA115	115	113 – 117	4"	19x1.8	200	M8+M10	
ABGA140	140	138 – 142	5"	19x2.3	200	M8+M10	
ABGA160	160	158 – 162	6"	19x2.3	200	M8+M10	

DRAWING

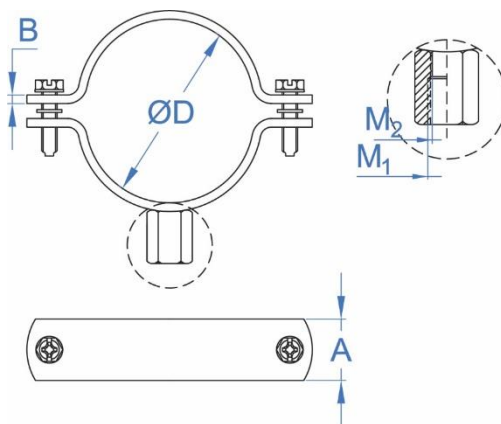

2.2 AB-GS

Black coated pipe clamp for gas M6



Coating



Black painted

Base Materials



Steel Piping



Copper Piping



Plastic Piping

Installation data

Code	Ø D (mm)	Ø D (")	A x B (mm)	Recommended Load (kg)	Characteristics
ABGS010	10	1/8	12,0 x 1,2	70	<ul style="list-style-type: none"> • For piping from Ø10 to Ø54 mm. • Surface finish: painted black, allowing easy identification of gas installations. • Steel profile, 1.2 mm thick. • Lateral opening for faster installation. • Encased M6 nut, with pre-assembled M6x30 screw. • Suitable for steel, plastic and copper piping, and gas piping. • Especially suitable for gas installations. • According to UNE-EN ISO 4892
ABGS012	12	1/4	12,0 x 1,2	70	
ABGS015	15	--	12,0 x 1,2	70	
ABGS018	18	3/8	12,0 x 1,2	70	
ABGS022	22	1/2	12,0 x 1,2	70	
ABGS028	28	--	12,0 x 1,2	70	
ABGS035	35	--	12,0 x 1,2	70	
ABGS042	42	1 1/4	12,0 x 1,2	100	
ABGS054	54	--	12,0 x 1,2	100	

DRAWING

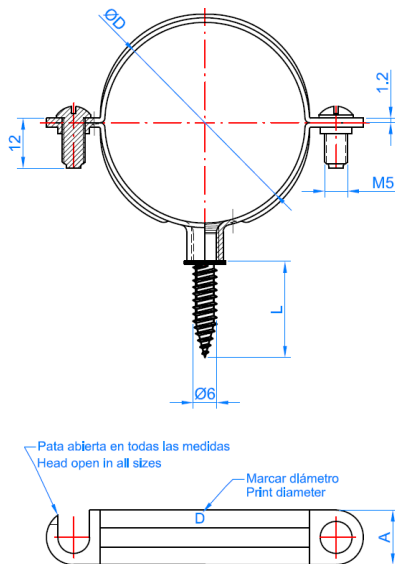

APPLICATION EXAMPLES



2.3 AB-GD

Double black coated pipe clamp for gas M6



Coating



Black painted

Base Materials



Steel Piping



Copper Piping



Plastic Piping

Installation data

Code	ØB (mm)	Ø B (")	E x C (mm)	Recommended Load (kg)	Characteristics
ABGD012	12	1/8	12 ÷ 1,2	100	<ul style="list-style-type: none"> • For piping from Ø12 to Ø28 mm. • Surface finish: painted black, allowing easy identification of gas installations. • Steel profile, 0.8÷1.5 mm thick. • Encased M6 nut, with pre-assembled M6x30 screw. • Suitable for steel, plastic and copper piping, and gas piping. • Especially suitable for gas installations. • According to UNE-EN ISO 4892
ABGD015	15	1/4	12 ÷ 1,2	100	
ABGD018	18	3/8	12 ÷ 1,2	100	
ABGD022	22	1/2	12 ÷ 1,2	100	
ABGD028	28	3/4	12 ÷ 1,2	100	

DRAWING

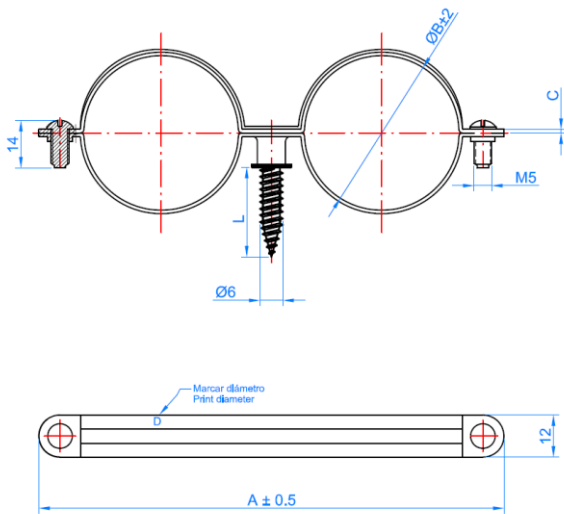

APPLICATION EXAMPLES



2.4 AB-GM

Yellow coated pipe clamp for gas M6



Coating



Yellow painted

Base Materials



Steel Piping



Copper Piping



Plastic Piping

Installation data

Code	ØD (mm)	ØD (")	A x C (mm)	Recommended Load (kg)	Characteristics
ABGM012	12	1/4	12 ÷ 1,2	70	<ul style="list-style-type: none"> • For piping from Ø12 to Ø35 mm. • Surface finish: painted yellow, allowing easy identification of gas installations • Steel profile, 1.2 mm thick. • Lateral opening for faster installation. • Encased M6 nut, with pre-assembled M6x30 screw. • Suitable for steel, plastic and copper piping, and gas piping. • Especially suitable for gas installations. • According to UNE-EN ISO 4892
ABGM015	15	--	12 ÷ 1,2	70	
ABGM018	18	3/8	12 ÷ 1,2	70	
ABGM022	22	1/2	12 ÷ 1,2	70	
ABGM028	28	--	12 ÷ 1,2	70	
ABGM035	35	--	12 ÷ 1,2	70	

DRAWING

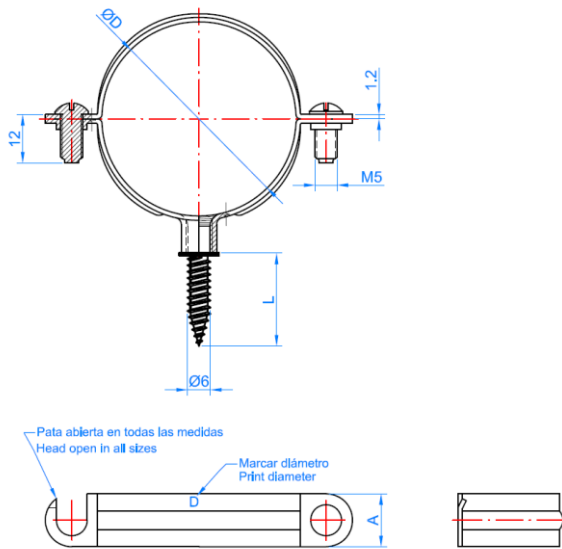

APPLICATION EXAMPLES

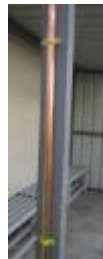

2.5 AB-IP

Pipe clip for fixing plate



Coating



Zinc plated

Base Materials



Steel Piping



Copper Piping



Plastic Piping

Installation data

Code	ØD (mm)	ØD (")	A x B (mm)	Nº of holes	Characteristics
ABIP015	15	1/4	19 x 1,5	3	<ul style="list-style-type: none"> • For piping from Ø15 to Ø90 mm. • Surface finish: Zinc plated ≥ 3 microns. • Steel profile, 1.5 mm thick. • Quick and easy to install. • Especially for assembly on an isophonic base, with parallel piping. • Compliant with the Technical Building Code (TBC), HS and HR Basic Requirements sections. • Installation temperature: -30°C ÷ +120°C. • Suitable for sanitary installation, light piping, gas, etc.
ABIP018	18	3/8	19 x 1,5	3	
ABIP022	22	1/2	19 x 1,5	3	
ABIP026	26	3/4	19 x 1,5	4	
ABIP028	28	--	19 x 1,5	4	
ABIP035	35	1	19 x 1,5	4	
ABIP042	42	1 1/4	19 x 1,5	4	
ABIP048	48	1 1/2	19 x 1,5	4	
ABIP054	54	1 3/4	19 x 1,5	5	
ABIP060	60	2	19 x 1,5	5	
ABIP067	67	--	19 x 1,5	5	
ABIP075	75	2 1/2	19 x 1,5	6	
ABIP090	90	3	19 x 1,5	6	

DRAWING

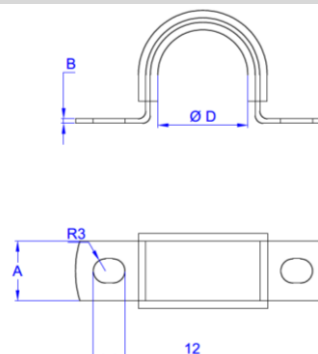



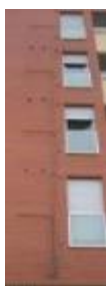

APPLICATION EXAMPLES



2.6 AB-SI

Fixing plate for pipe clip

	Coating	Base Materials		
				
	Zinc plated	Steel Piping	Copper Piping	Plastic Piping

Installation data

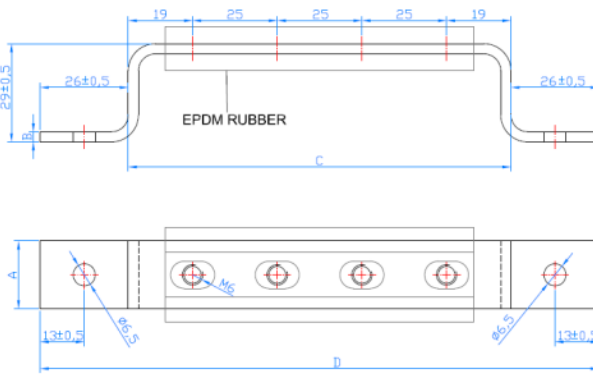
Code	A X B (mm)	C (mm)	D (mm)	N° of holes	Characteristics
ABSI03	20,0 x 3,0	88	140	3	<ul style="list-style-type: none"> • For piping from $\varnothing 15$ to $\varnothing 90$ mm. • Surface finish: Zinc plated ≥ 5 microns. • Steel profile, 3 mm thick. • Quick and easy to install. • Especially for assembly on an isophonic base. • Installation temperature: $-30^{\circ}\text{C} \div +120^{\circ}\text{C}$. • Suitable for sanitary installation, light piping, gas, etc.
ABSI04	20,0 x 3,0	113	165	4	
ABSI05	20,0 x 3,0	138	190	5	
ABSI06	20,0 x 3,0	163	215	6	
ABSI07	20,0 x 3,0	188	240	7	
ABSI08	20,0 x 3,0	213	265	8	
ABSI09	20,0 x 3,0	238	290	9	
ABSI10	20,0 x 3,0	263	315	10	
ABSI11	20,0 x 3,0	288	340	11	
ABSI12	20,0 x 3,0	313	365	12	
ABSI13	20,0 x 3,0	338	390	13	<p>DRAWING</p> 
ABSI14	20,0 x 3,0	363	415	14	
ABSI15	20,0 x 3,0	388	440	15	
ABSI16	20,0 x 3,0	413	465	16	
ABSI17	20,0 x 3,0	438	490	17	
ABSI18	20,0 x 3,0	463	515	18	
ABSI19	20,0 x 3,0	488	540	19	
ABSI20	20,0 x 3,0	513	565	20	
ABSI21	20,0 x 3,0	538	590	21	
ABSI22	20,0 x 3,0	563	615	22	
ABSI23	20,0 x 3,0	588	640	23	
ABSI24	20,0 x 3,0	613	665	24	
ABSI25	20,0 x 3,0	638	690	25	

APPLICATION EXAMPLES



2.7 AB-TO

Screw for isophonic bridge clamps



Coating



Zinc plated

Base Materials



Steel Piping



Copper Piping



Plastic Piping

Datos de Instalación

Code	ØM	L	Huella
ABTO06015	M6	15 ÷ 17.5	Hexagonal Head + Recess + PH3

DRAWING

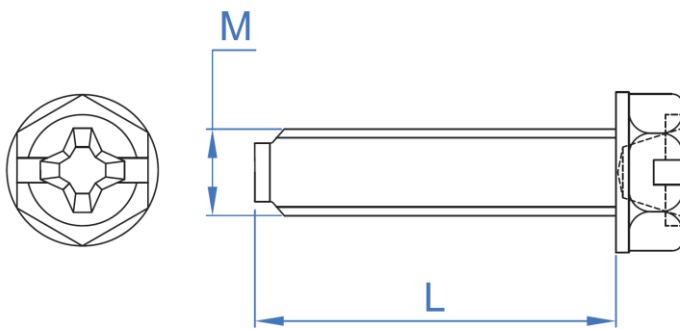

Characteristics

- Metric thread screw designed for fastening isophonic pipe clamps.
- Compatible with AB-IP clamps and AB-SI clamp brackets.
- Manufactured from zinc-plated steel for enhanced corrosion resistance.
- Ensures easy, fast, and secure installation.
- Provides a firm and reliable pipe fixing.
- Suitable for HVAC, plumbing, and electrical installations.
- Recommended for applications involving pipe clamps and support systems in construction.

APPLICATION EXAMPLES

