



**INSTITUTO DE CIENCIAS
DE LA CONSTRUCCIÓN
EDUARDO TORROJA**
C/ Serrano Galvache, 4. 28033 Madrid (Spain)
Tel.: (+34) 91 302 0440 www.ietcc.csic.es
gestiondit@ietcc.csic.es dit.ietcc.csic.es



European Technical Assessment

ETA-18/1108
of 18/01/2026

General Part

Technical Assessment Body issuing the European Technical Assessment:
Instituto de Ciencias de la Construcción Eduardo Torroja (IETCC)

Trade name of the construction product

Anchors SLPT

Product family to which the construction product belongs

Torque controlled expansion anchor made of steel of sizes M6, M8, M10, M12, M16 and M20 for use in concrete.

Manufacturer

Index - Técnicas Expansivas S.L.
Segador 13
26006 Logroño (La Rioja) Spain.
website: www.indexfix.com

Manufacturing plant

Index plant 2

This European Technical Assessment contains

17 pages,
including annexes 1-10, which form an integral part of this assessment.
+ Annex 11. Contain confidential information and is not included in the ETA when that assessment is publicly available

This European Technical Assessment is issued in accordance with Article 95(4) of Regulation (EU) 2024/3110, on the basis of

EAD 330232-02-0601:
"Mechanical Fasteners for use in concrete" ed. September 2024.

This ETA replaces

ETA 18/1108 revision 4 dated 14/03/2025

Translations of this European Technical Assessment in other languages shall fully correspond to the original issued document and should be identified as such.

Communication of this European Technical Assessment, including transmission by electronic means, shall be in full (excepted the confidential Annex(es) referred to above). However, partial reproduction may be made, with the written consent of the issuing Technical Assessment Body. Any partial reproduction has to be identified as such.



SPECIFIC PART

1. Technical description of the product

The Index SLPT heavy duty anchor is a torque controlled, sleeve type, mechanical expansion anchor comprised of 7 components which vary slightly according to anchor diameter. The anchor is installed into a predrilled cylindrical hole and anchored by torque-controlled expansion. Application of a torque on the head of the anchor causes the cone to be drawn into the expansion sleeve. This in turn causes the sleeve to expand against the wall of the drilled hole. The ribs of the plastic element prevent rotation of the sleeve and cone during application of torque. Application of a specific installation torque induces a tension force in the bolt that is equilibrated by a compression force in the concrete acting through the component being fastened. Application of tension loads that exceed the compression force in the bolt will cause the cone to displace further into the expansion sleeve (follow up expansion) generating additional expansion force. The anchorage is characterised by friction between the expansion sleeve and the concrete.

The Index SLPT heavy duty anchor in the range M6, M8, M10, M12, M16 and M20 is an anchor made of galvanised steel. SLPT, SLAT, SLPS, SLAS anchors have a hexagonal head; SLPC, SLAC anchors have countersunk head and the SLPE, SLAE are the projecting bolt version.

Product and installation descriptions are given in annexes A and B.

2. Specification of the intended use in accordance with the applicable European Assessment Document.

2.1 Intended use

This ETA covers fasteners to be used in compacted, reinforced or unreinforced, normal weight, cracked or uncracked concrete without fibers with strength classes in the range of C20/25 to C50/60 all in accordance with EN 206-1, for static or quasi-static or under seismic actions (categories C1 and C2) and with requirements related to fire exposure, loaded in tension, shear or combined tension and shear.

The performances given in section 3 are only valid if the anchor is used in compliance with the specifications and conditions given in annexes A, B and C.

2.2 Relevant general conditions for the use of the product

The assessment methods included or referred to in this EAD have been written based on the manufacturer's request to take into account a working life of the fastener for the intended use of 50 years when installed in the works (provided that the fastener is subject to appropriate installation). These provisions are based upon the current state of the art and the available knowledge and experience.

When assessing the product, the intended use as foreseen by the manufacturer shall be taken into account. The real working life may be, in normal use conditions, considerably longer without major degradation affecting the basic requirements for works.

The indications given as to the working life of the construction product cannot be interpreted as a guarantee neither given by the product manufacturer or its representative nor by EOTA when drafting the EAD nor by the Technical Assessment Body issuing an ETA based on this EAD, but are regarded only as a mean for expressing the expected economically reasonable working life of the product.

This ETA covers fasteners for installation in pre-drilled holes in compacted reinforced or unreinforced normal weight concrete without fibers considering annexes A, B and C.



3. Performance of the product and references to the methods used for its assessment

The identification tests and the assessment for the intended use of this product according to the Basic Work Requirements (BWR) were carried out in compliance with EAD 330232-02-0601. The characteristics of each system shall correspond to the respective values laid down in following tables of this ETA, checked by IETcc.

Methods of verification and of assessing and judging are listed afterwards.

3.1 Mechanical resistance and stability (BWR 1)

Essential characteristic	Relevant clause in EAD	Performance	Annex
Resistance to steel failure under tension load	2.2.1	$N_{Rk,s}$ [kN]	C3, C4
Resistance to pull-out failure	2.2.2	$N_{Rk,p,ucr}$ [kN], $N_{Rk,p,cr}$ [kN], $\psi_{c,cr}$ [-], $\psi_{c,ucr}$ [-]	C3, C4
Resistance to concrete cone failure	2.2.3	$k_{cr,N}$ [-], $k_{ucr,N}$ [-], h_{ef} [mm], $c_{cr,N}$ [mm]	C3, C4
Robustness	2.2.4	γ_{inst} [-]	C3, C4
Minimum edge distance and spacing	2.2.5	c_{min} [mm], s_{min} [mm], h_{min} [mm]	C1
Edge distance to prevent splitting under load	2.2.6	$N_{Rk,sp}^0$ [kN], $c_{cr,sp}$ [mm]	C3, C4
Resistance to steel failure under shear load	2.2.7	$V_{Rk,s}^0$ [kN], $M_{Rk,s}^0$ [Nm], k_7 [-]	C5, C6
Resistance to pry-out failure	2.2.8	k_8 [-]	C5, C6
Displacement under static and quasi-static loading	2.2.10	δ_{N0} , [mm], $\delta_{N\infty}$ 50 years [mm], δ_{V0} [mm], $\delta_{V\infty}$ [mm]	C3 to C6
Stiffness in the elastic range under tension loading	2.2.11.1	NPD	--
Stiffness characteristics for tension loading for non-linear spring models	2.2.11.2	NPD	--
Resistance to tension load for seismic performances category C1	2.2.12	$N_{Rk,s,C1}$ [kN], $N_{Rk,p,C1}$ [kN]	C7
Resistance to shear load for seismic performances category C1, factor for annular gap	2.2.13	$V_{Rk,s,C1}$ [kN]	C7
Resistance to tension load and displacements for seismic performances category C2	2.2.14	$N_{Rk,s,C2}$, $N_{Rk,p,C2}$ [kN], $\delta_{N,C2(0.5)}$ [mm], $\delta_{N,C2(0.8)}$ [mm]	C8
Resistance to shear load and displacements for seismic performances category C2, factor for annular gap	2.2.15	$V_{Rk,s,C2}$ [kN], $\delta_{V,C2(0.5)}$ [mm], $\delta_{V,C2(0.8)}$ [mm]	C8



3.2 Safety in case of fire (BWR 2)

Essential characteristic	Relevant clause in EAD	Performance	Annex
Reaction to fire	2.2.16	Anchorage satisfy requirements for class A1 according to EN 13501-1	--
Fire resistance to steel failure, tension load	2.2.17	$N_{Rk,s,fi}$ [kN]	C9, C10
Fire resistance to pull out failure, tension load	2.2.18	$N_{Rk,p,fi}$ [kN]	C9, C10
Fire resistance to steel failure, shear load	2.2.19	$V_{Rk,s,fi}$ [kN], $M^0_{Rk,s,fi}$ [Nm]	C9, C10

3.3 Durability

Essential characteristic	Relevant clause in EAD	Performance	Annex
Durability: SLPT, SLPC, SLPE, SLPS SLAT, SLAC, SLAE, SLAS	2.2.20	Coated in zinc plated Coated in zinc nickel	A2

4. Assessment and Verification of Constancy of Performance (hereinafter AVCP) system applied, with reference to its legal base

The applicable European legal act for the system of Assessment and Verification of Constancy of Performance (see annex V to Regulation (EU) No 305/2011) is 96/582/EC.

The system to be applied is 1.

5. Technical details necessary for the implementation of the AVCP system, as provided for in the applicable European Assessment Document.

Technical details necessary for the implementation of the AVCP system are laid down in the quality plan which is deposited at IETcc⁽¹⁾.

Prepared by: PhD Julián Rivera (Innovative Products Assessment Unit, IETcc-CSIC)
Issued in Madrid on 18th of January 2026

Director
on behalf of Instituto de Ciencias de la Construcción Eduardo Torroja (IETcc – CSIC)

⁽¹⁾ The Quality Plan is a confidential part of the ETA and only handed over to the notified certification body involved in the assessment and verification of constancy of performance.



Product and installed condition

SLPT, SLAT, SLPS, SLAS anchors

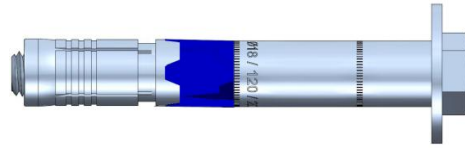

SLPC, SLAC anchors

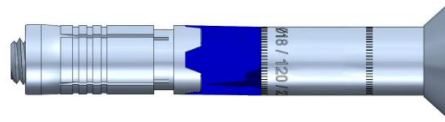

SLPE, SLAE anchors



Identification on anchor:

- Sleeve: SLPT / SLAT / SLPS / SLAS / SLPE / SLAE: outer diameter / total length / maximum fixture thickness to be fixed.
 SLPC / SLAC: "C" / outer diameter / total length / maximum fixture thickness to be fixed
- Plastic ring: anchor name "SLP", company logo

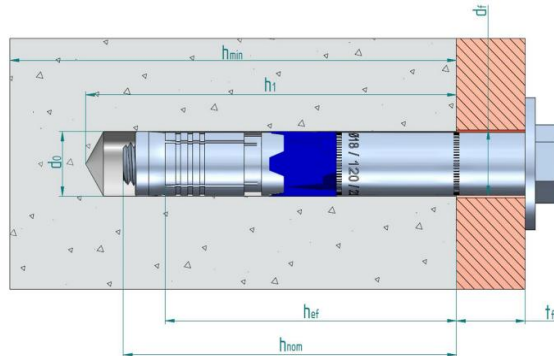

- do: Nominal diameter of drill bit
- di: Fixture clearance hole diameter
- hef: Effective anchorage depth
- h1: Depth of drilled hole
- hnom: Overall anchor embedment depth in the concrete
- hmin: Minimum thickness of concrete member
- tfix: Fixture thickness

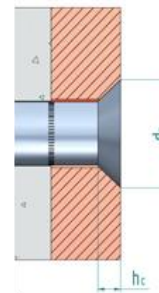

SLPT anchor

Product description

Installed condition

Annex A1



Table A1: Materials					
Item	Designation	Material for SLPT	Material for SLPS	Material for SLPC	Material for SLPE
1	Bolt	DIN 931 ISO 898-1 class 8.8. Galvanized $\geq 5 \mu\text{m}$ ISO 4042 Zn5/An/T0		DIN 7991 ISO 898-1 class 10.9. Galvanized $\geq 5 \mu\text{m}$ ISO 4042 Zn5/An/T0	---
2	Projecting bolt	---		---	Threaded stud class 8.8 ISO 898-1. Galvanized $\geq 5 \mu\text{m}$ ISO 4042 Zn5/An/T0
3	Nut	---		---	Standard nut class 8. Galvanized $\geq 5 \mu\text{m}$ ISO 4042 Zn5/An/T0
4	Washer	DIN 9021 or DIN 440. Galvanized $\geq 5 \mu\text{m}$ ISO 4042 Zn5/An/T0		Special conical washer. Galvanized $\geq 5 \mu\text{m}$ ISO 4042 Zn5/An/T0	DIN 9021 or DIN 440. Galvanized $\geq 5 \mu\text{m}$ ISO 4042 Zn5/An/T0
5	Sleeve	Carbon steel. Galvanized $\geq 5 \mu\text{m}$ ISO 4042 Zn5/An/T0			
6	Plastic ring	POM			
7	Expansion sleeve	Carbon steel. Galvanized $\geq 5 \mu\text{m}$ ISO 4042 Zn5/An/T0			
8	Cone	Hardened carbon steel. Galvanized $\geq 5 \mu\text{m}$ ISO 4042 Zn5/An/T0			
Item	Designation	Material for SLAT	Material for SLAS	Material for SLAC	Material for SLAE
1	Bolt	DIN 931 ISO 898-1 class 8.8. Zinc nickel $\geq 8 \mu\text{m}$, sealed ISO 4042 ZnNi8/An/T2		DIN 7991 ISO 898-1 class 10.9. Zinc nickel $\geq 8 \mu\text{m}$, sealed ISO 4042 ZnNi8/An/T2	---
2	Projecting bolt	---		---	Threaded stud class 8.8 ISO 898-1. Zinc nickel $\geq 8 \mu\text{m}$, sealed ISO 4042 ZnNi8/An/T2
3	Nut	---		---	Standard nut class 8. Zinc nickel $\geq 8 \mu\text{m}$, sealed ISO 4042 ZnNi8/An/T2
4	Washer	DIN 9021 or DIN 440. Zinc nickel $\geq 8 \mu\text{m}$, sealed ISO 4042 ZnNi8/An/T2		Special conical washer. Zinc nickel $\geq 8 \mu\text{m}$, sealed ISO 4042 ZnNi8/An/T2	DIN 9021 or DIN 440. Zinc nickel $\geq 8 \mu\text{m}$, sealed ISO 4042 ZnNi8/An/T2
5	Sleeve	Carbon steel. Zinc nickel $\geq 8 \mu\text{m}$, sealed ISO 4042 ZnNi8/An/T2			
6	Plastic ring	POM			
7	Expansion sleeve	Carbon steel. Zinc nickel $\geq 8 \mu\text{m}$, sealed ISO 4042 ZnNi8/An/T2			
8	Cone	Hardened carbon steel. Zinc nickel $\geq 8 \mu\text{m}$, sealed ISO 4042 ZnNi8/An/T2			
SLPT anchor					Annex A2
Product description					
Materials					



Specifications of intended use

Version	Intended use	M6 Ø10	M8 Ø12	M10 Ø16	M12 Ø18	M16 Ø24	M20 Ø28
SLPT/SLAT SLPC/SLAC SLPE/SLAE	Static or quasi static loads	✓	✓	✓	✓	✓	✓
	Seismic loads category C1		✓	✓	✓	✓	✓
	Seismic loads category C2		✓	✓	✓	✓	✓
	Resistance to fire exposure	✓	✓	✓	✓	✓	✓
SLPS/SLAS	Static or quasi static loads				✓		
	Seismic loads category C1				✓		
	Seismic loads category C2				✓		
	Resistance to fire exposure				✓		

Base materials:

- Compacted reinforced or unreinforced normal weight concrete without fibres according to EN 206-1:2013 + A2:2021.
- Strength classes C20/25 to C50/60 according to EN 206-1:2013 + A2:2021.
- Cracked or uncracked concrete

Use conditions (environmental conditions):

- Temperature range of the anchorage base material during the working life: -40 °C to +80 °C
- Anchorages subjected to dry internal conditions.

Design:

- Anchorages are designed under the responsibility of an engineer experienced in anchorages and concrete.
- Verifiable calculation rules and drawings are prepared taking into considering the loads to be anchored. The position of the anchor is indicated on the design drawings (e.g., position of the anchor relative to reinforcement or to supports, etc.).
- Anchorages under static or quasi-static actions are designed for design method A in accordance with EN 1992-4:2018
- Anchorages under seismic actions are designed in accordance with EN 1992-4:2018. Anchorages shall be positioned outside of critical regions (e.g. plastic hinges) of the concrete structure. Fastening in stand-off installation or with grout layer are not allowed.
- Anchorages under fire exposure are designed in accordance with EN 1992-4:2018. It must be ensured that local spalling of the concrete cover does not occur.

Installation:

- Hole drilling by rotary plus hammer mode.
- Anchor installation carried out by appropriately qualified personal and under the supervision of the person responsible for technical matters of the site.
- In case of aborted hole: new drilling at a minimum distance away of twice the depth of aborted hole or smaller distance if the aborted hole is filled with non-shrinkage mortar with a strength at least or equal of the base material and $\geq 40 \text{ N/mm}^2$.

SLPT anchor	Annex B1
Intended use	
Specifications	



Table C1: Installation parameters SLPT, SLAT, SLPC, SLAC, SLPE, SLAE

Installation parameters			Performances					
			M6 Ø10	M8 Ø12	M10 Ø16	M12 Ø18	M16 Ø24	M20 Ø28
d ₀	Nominal diameter of drill bit:	[mm]	10	12	16	18	24	28
d _f	Fixture clearance hole dia. ≤	[mm]	12	14	18	20	26	31
T _{inst}	Nominal installation torque:	[Nm]	15	30	50	80	160	240
h _{min}	Min. thickness of concrete member:	[mm]	100	120	140	170	200	250
h ₁	Depth of drilled hole ≥	[mm]	70	85	95	110	130	160
h _{nom}	Overall anchor embedment depth in the concrete:	[mm]	59	72	83	97	117	146
h _{ef}	Effective anchorage depth:	[mm]	50	60	70	85	100	125
t _{fix}	Thickness of fixture DIN 9021 ≤ ¹⁾	[mm]	L - 60	L - 75	L - 85	L - 100	L - 120	L - 150
t _{fix}	Thickness of fixture DIN 440 ≤ ¹⁾	[mm]	L - 61	L - 76	L - 86	L - 101	L - 121	L - 151
S _{min}	Minimum spacing in uncracked concrete:	[mm]	60	70	80	100	125	150
	for c ≥	[mm]	125	150	195	220	255	405
C _{min}	Minimum edge distance in uncracked concrete:	[mm]	50	60	70	80	100	160
	for s ≥	[mm]	100	120	175	200	220	320
S _{min}	Minimum spacing in cracked concrete:	[mm]	50	70	70	80	120	120
	for c ≥	[mm]	95	110	145	165	190	310
C _{min}	Minimum edge distance in cracked concrete:	[mm]	50	60	70	80	100	160
	for s ≥	[mm]	60	70	80	100	125	150
d _c	Diameter of countersunk head in the fixture:	[mm]	16.4	20.6	26.8	30.8	38.8	44.8
h _c	Height of countersunk head in the fixture:	[mm]	3.2	4.3	5.4	6.4	7.4	8.4
SW	SLPT / SLAT / SLPE / SLAE socket size:	[--]	10	13	17	19	24	30
SW	SLPC / SLAC hexagonal recess:	[--]	4	5	6	8	10	12

¹⁾ L = total anchor length

Table C2: Installation parameters SLPS, SLAS

Installation parameters			Performances	
			SLPS	SLAS
d ₀	Nominal diameter of drill bit:	[mm]	18	
d _f	Fixture clearance hole dia. ≤	[mm]	20	
T _{inst}	Nominal installation torque:	[Nm]	80	40
h _{min}	Min. thickness of concrete member:	[mm]	125	
h ₁	Depth of drilled hole ≥	[mm]	90	
h _{nom}	Overall anchor embedment depth in the concrete:	[mm]	78	
h _{ef}	Effective anchorage depth:	[mm]	68	
t _{fix}	Thickness of fixture DIN 9021 ≤ ¹⁾	[mm]	L - 83	
t _{fix}	Thickness of fixture ¹⁾ DIN 440 ≤ ¹⁾ ≤	[mm]	L - 84	
S _{min}	Minimum spacing:	[mm]	205	
C _{min}	Minimum edge distance:	[mm]	110	
SW	Socket size:	[--]	22	

¹⁾ L = total anchor length

SLPT anchor	Annex C1
Performances	
Installation parameters	



Installation procedure

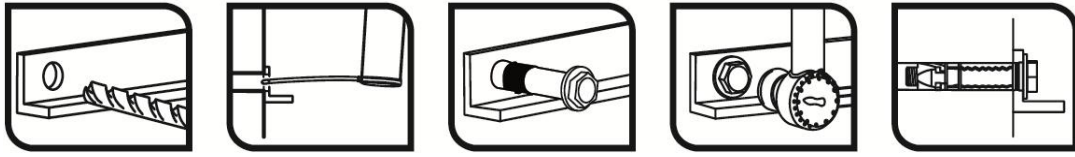

SLPT anchor	Annex C2
Performances Installation procedure	



Table C3: Characteristic values to tension loads of design method A according to EN 1992-4 for SLPT, SLAT, SLPC, SLAC, SLPE, SLAE anchors

Characteristic values of resistance to tension loads of design according to design method A			Performances						
			M6 Ø10	M8 Ø12	M10 Ø16	M12 Ø18	M16 Ø24	M20 Ø28	
Resistance to steel failure									
$N_{Rk,s}$	Characteristic resistance:	[kN]	16.1	29.3	46.4	67.4	126.0	196.0	
γ_{Ms}	Partial safety factor: ¹⁾	[-]	1.5						
Resistance to pull-out failure									
$N_{Rk,p,ucr}$	Characteristic resistance in C20/25 uncracked concrete:	[kN]	15.0	20.0	$\geq N_{Rk,c}^{2)}$				
$N_{Rk,p,cr}$	Characteristic resistance in C20/25 cracked concrete:	[kN]	$\geq N_{Rk,c}^{2)}$						
γ_{inst}	Robustness:	[-]	1.0	1.0	1.0	1.0	1.0	1.0	
$\psi_{c,ucr}$ $\psi_{c,cr}$	Increasing factor for $N_{Rk,p}$:	C30/37	[-]	1.22	1.22	1.22	1.22	1.08	1.08
		C40/50	[-]	1.41	1.41	1.41	1.41	1.15	1.15
		C50/60	[-]	1.58	1.58	1.58	1.58	1.20	1.20
Resistance to concrete cone and splitting failure									
h_{ef}	Effective embedment depth:	[mm]	50	60	70	85	100	125	
$k_{ucr,N}$	Factor for uncracked concrete:	[-]	11.0						
$k_{cr,N}$	Factor for cracked concrete:	[-]	7.7						
γ_{inst}	Robustness:	[-]	1.0	1.0	1.0	1.0	1.0	1.0	
$s_{cr,N}$	Spacing, edge distance for concrete cone failure:	[mm]	$3 \times h_{ef}$						
$s_{cr,N}$		[mm]	$1.5 \times h_{ef}$						
$N_{Rk,sp}^0$	Characteristic splitting resistance:	[kN]	$\min(N_{Rk,p}; N_{Rk,c})$						
$s_{cr,sp}$	Spacing, edge distance for splitting failure:	[mm]	205	245	285	345	410	510	
$s_{cr,sp}$		[mm]	105	125	145	175	205	255	

1) In absence of other national regulations

2) Pull out failure is not decisive. $N_{Rk,c}$ calculated according to EN 1992-4

Table C4: Displacements under static and quasi-static tension loading for SLPT, SLAT, SLPC, SLAC, SLPE, SLAE anchors

Displacements under tension loading			Performances					
			M6 Ø10	M8 Ø12	M10 Ø16	M12 Ø18	M16 Ø24	M20 Ø28
N	Service tension load in uncracked concrete C20/25 to C50/60:	[kN]	7.43	10.24	13.71	18.38	19.52	27.30
δ_{N0}	Short term displacement:	[mm]	1.18	2.02	1.79	1.15	2.46	2.12
$\delta_{N50\text{ years}}$	Long term displacement:	[mm]	2.68	2.68	2.68	2.68	2.68	2.68
N	Service tension load in cracked concrete C20/25 to C50/60:	[kN]	5.81	7.62	9.62	12.86	13.65	19.09
δ_{N0}	Short term displacement:	[mm]	1.75	2.69	2.57	3.53	1.76	2.41
$\delta_{N50\text{ years}}$	Long term displacement:	[mm]	3.75	4.69	4.57	5.53	3.76	4.41

SLPT anchor

Performances

Characteristic values for tension loads

Annex C3



Table C5: Characteristic values to tension loads of design method A according to EN 1992-4 for SLPS, SLAS anchors

Characteristic values of resistance to tension loads of design according to design method A			Performances	
			M12 Ø18	
Resistance to steel failure				
$N_{Rk,s}$	Characteristic resistance:	[kN]	67.4	
γ_{Ms}	Partial safety factor: ¹⁾	[-]	1.5	
Resistance to pull-out failure				
$N_{Rk,p,ucr}$	Characteristic resistance in C20/25 uncracked concrete:	[kN]	$\geq N_{Rk,c}^{2)}$	
$N_{Rk,p,cr}$	Characteristic resistance in C20/25 cracked concrete:	[kN]	$\geq N_{Rk,c}^{2)}$	
γ_{inst}	Robustness:	[-]	1.0	
$\Psi_{c,ucr}$	Increasing factor for $N_{Rk,p}$ for uncracked concrete:	C30/37	[-]	1.22
		C40/50	[-]	1.41
		C50/60	[-]	1.58
$\Psi_{c,ctr}$	Increasing factor for $N_{Rk,p}$ for cracked concrete:	C30/37	[-]	1.03
		C40/50	[-]	1.06
		C50/60	[-]	1.08
Resistance to concrete cone and splitting failure				
h_{ef}	Effective embedment depth:	[mm]	68	
$k_{ucr,N}$	Factor for uncracked concrete:	[-]	11.0	
$k_{cr,N}$	Factor for cracked concrete:	[-]	7.7	
γ_{inst}	Robustness:	[-]	1.0	
$s_{cr,N}$	Spacing, edge distance for concrete cone failure:	[mm]	$3 \times h_{ef}$	
$c_{cr,N}$		[mm]	$1.5 \times h_{ef}$	
$N_{Rk,sp}^0$	Characteristic splitting resistance:	[kN]	$\min(N_{Rk,p}; N_{Rk,c})$	
$s_{cr,sp}$	Spacing, edge distance for splitting failure:	[mm]	440	
$c_{cr,sp}$		[mm]	220	

¹⁾ In absence of other national regulations

²⁾ Pull out failure is not decisive. $N_{Rk,c}$ calculated according to EN 1992-4

Table C6: Displacements under static and quasi-static tension loading for SLPS, SLAS anchors

Displacements under tension loading			Performances	
			M12 Ø18	
N	Service tension load in uncracked concrete C20/25 to C50/60:	[kN]	13.13	
δ_{N0}	Short term displacement:	[mm]	2.75	
$\delta_{N50 \text{ years}}$	Long term displacement:	[mm]	3.45	
N	Service tension load in cracked concrete C20/25 to C50/60:	[kN]	9.20	
δ_{N0}	Short term displacement:	[mm]	1.97	
$\delta_{N50 \text{ years}}$	Long term displacement:	[mm]	2.67	

SLPT anchor

Performances

Characteristic values for tension loads

Annex C4



Table C7: Characteristic values to shear loads of design method A according to EN 1992-4 for SLPT, SLAT, SLPC, SLAC, SLPE, SLAE anchors

Characteristic values of resistance to shear loads of design according to design method A			Performances					
			M6 Ø10	M8 Ø12	M10 Ø16	M12 Ø18	M16 Ø24	M20 Ø28
Resistance to steel failure under shear loads								
$V_{Rk,s}^0$	Characteristic resistance:	[kN]	20.2	33.0	62.2	75.1	111.2	141.7
k_T	Ductility factor:	[-]	1.0					
$M_{Rk,s}^0$	Characteristic bending moment:	[Nm]	12.2	30.0	59.8	104.8	266.4	519.3
γ_{Ms}	Partial safety factor: ¹⁾	[-]	1.25					
Resistance to pry-out failure								
k_B	Pryout factor:	[-]	3.2	3.0	3.4	3.6	4.3	4.3
γ_{inst}	Robustness:	[-]	1.0					
Resistance to concrete edge failure								
l_f	Effective length of anchor under shear loads:	[mm]	50	60	70	85	100	125
d_{nom}	Outside anchor diameter:	[mm]	10	12	16	18	24	28
γ_{inst}	Robustness:	[-]	1.0					

¹⁾ In absence of other national regulations

Table C8: Displacements under static and quasi-static shear loading for SLPT, SLAT, SLPC, SLAC, SLPE, SLAE anchors

Displacements under shear loading			Performances					
			M6 Ø10	M8 Ø12	M10 Ø16	M12 Ø18	M16 Ø24	M20 Ø28
V	Service shear load in uncracked and cracked concrete C20/25 to C50/60:	[kN]	9.62	15.71	29.62	35.76	44.13	56.23
δ_{V0}	Short term displacement:	[mm]	2.15	1.22	1.31	1.72	1.41	1.96
$\delta_{V\infty}$	Long term displacement:	[mm]	3.23	1.83	1.96	2.58	2.11	2.93

SLPT anchor

Performances

Characteristic values for shear loading

Annex C5



Table C9: Characteristic values to shear loads of design method A according to EN 1992-4 for SLPS, SLAS anchors

Characteristic values of resistance to shear loads of design according to design method A			Performances	
			M12 Ø18	
Resistance to steel failure under shear loads				
$V_{Rk,s}^0$	Characteristic resistance:	[kN]	74.8	
k_{τ}	Ductility factor:	[-]	1.0	
$M_{Rk,s}^0$	Characteristic bending moment:	[Nm]	104.8	
γ_{Ms}	Partial safety factor: ¹⁾	[-]	1.25	
Resistance to pry-out failure				
k_{β}	Pryout factor:	[-]	2.0	
γ_{inst}	Robustness:	[-]	1.0	
Resistance to concrete edge failure				
l_f	Effective length of anchor under shear loads:	[mm]	68	
d_{nom}	Outside anchor diameter:	[mm]	18	
γ_{inst}	Robustness:	[-]	1.0	

¹⁾ In absence of other national regulations

Table C10: Displacements under static and quasi-static shear loading for SLPS, SLAS anchors

Displacements under shear loads			Performances	
			M12 Ø18	
V	Service shear load in uncracked and cracked concrete C20/25 to C50/60:	[kN]	35.62	
$\bar{\delta}_{V0}$	Short term displacement:	[mm]	3.56	
$\bar{\delta}_{V\infty}$	Long term displacement:	[mm]	5.33	

SLPT anchor

Performances

Characteristic values for shear loading

Annex C6



Table C11: Essential characteristics for seismic performance category C1 for SLPT, SLAT, SLPC, SLAC, SLPE, SLAE anchors

Essential characteristics for seismic performance category C1			Performances					
			M6 Ø10	M8 Ø12	M10 Ø16	M12 Ø18	M16 Ø24	M20 Ø28
Resistance to steel failure under tension loads								
$N_{Rk,s,C1}$	Characteristic tension resistance:	[kN]	--	29.3	46.4	67.4	126.0	196.0
γ_{Ms}	Partial safety factor: ¹⁾	[-]	--	1.5				
Resistance to steel failure under shear loads								
$V_{Rk,s,C1}$	Characteristic shear resistance:	[kN]	--	23.1	43.6	45.0	77.9	99.4
γ_{Ms}	Partial safety factor: ¹⁾	[-]	--	1.25				
Resistance to pull-out failure								
$N_{Rk,p,C1}$	Characteristic pull out failure:	[kN]	--	13.0	16.2	24.7	31.3	46.3
γ_{inst}	Robustness:	[-]	--	1.0	1.0	1.0	1.0	1.0
Resistance to concrete cone failure								
h_{ef}	Effective embedment depth:	[mm]	--	60	70	85	100	125
$s_{cr,N}$	Spacing:	[mm]	--	3 x h_{ef}				
$c_{cr,N}$	Edge distance:	[mm]	--	1.5 x h_{ef}				
γ_{inst}	Robustness:	[-]	--	1.0	1.0	1.0	1.0	1.0

¹⁾ In absence of other national regulations

Table C12: Essential characteristics for seismic performance category C1 for SLPS, SLAS anchors

Essential characteristics for seismic performance category C1			Performances	
			M12 Ø18	
Resistance to steel failure under tension loads				
$N_{Rk,s,C1}$	Characteristic tension resistance:	[kN]	67.4	
γ_{Ms}	Partial safety factor: ¹⁾	[-]	1.5	
Resistance to steel failure under shear loads				
$V_{Rk,s,C1}$	Characteristic shear resistance:	[kN]	44.8	
γ_{Ms}	Partial safety factor: ¹⁾	[-]	1.25	
Resistance to pull-out failure				
$N_{Rk,p,C1}$	Characteristic pull out failure:	[kN]	17.6	
γ_{inst}	Robustness:	[-]	1.0	
Resistance to concrete cone failure				
h_{ef}	Effective embedment depth:	[mm]	85	
$s_{cr,N}$	Spacing:	[mm]	3 x h_{ef}	
$c_{cr,N}$	Edge distance:	[mm]	1.5 x h_{ef}	
γ_{inst}	Robustness:	[-]	1.0	

¹⁾ In absence of other national regulations

SLPT anchor	Annex C7
Performances	
Essential characteristics for C1 seismic performances	



Table C13: Essential characteristics for seismic performance category C2 for SLPT, SLAT, SLPC, SLAC, SLPE, SLAE anchors

Essential characteristics for seismic performance category C2			Performances					
			M6 Ø10	M8 Ø12	M10 Ø16	M12 Ø18	M16 Ø24	M20 Ø28
Resistance to steel failure under tension loads								
N _{Rk,s,C2}	Characteristic tension steel failure:	[kN]	--	29.3	46.4	67.4	126.0	196.0
γ _{Ms}	Partial safety factor: ¹⁾	[-]				1.5		
Resistance to steel failure under shear loads								
V _{Rk,s,C2}	Characteristic shear steel failure:	[kN]	--	16.5	33.8	30.1	55.6	54.7
γ _{Ms}	Partial safety factor: ¹⁾	[-]	--			1.25		
Resistance to pull-out failure								
N _{Rk,p,C2}	Characteristic pull out failure:	[kN]	--	6.1	12.1	21.4	34.4	40.8
γ _{inst}	Robustness:	[-]	--	1.0	1.0	1.0	1.0	1.0
Resistance to concrete cone failure								
h _{ef}	Effective embedment depth:	[mm]	--	60	70	85	100	125
s _{cr,N}	Spacing:	[mm]	--	3 x h _{ef}				
c _{cr,N}	Edge distance:	[mm]	--	1.5 x h _{ef}				
γ _{inst}	Robustness:	[-]	--	1.0	1.0	1.0	1.0	1.0
Displacements								
Δ _{N,C2(0.5)}	Displacement Damage Limitation State:	[mm]	--	4.7	3.4	5.9	4.0	3.9
Δ _{V,C2(0.5)}		[mm]	--	4.9	5.2	5.8	6.0	6.1
Δ _{N,C2(0.8)}	Displacement Ultimate Limit State:	[mm]	--	16.4	10.9	19.0	11.9	10.5
Δ _{V,C2(0.8)}		[mm]	--	8.8	9.3	9.4	13.0	9.2

¹⁾ In absence of other national regulations

Table C14: Essential characteristics for seismic performance category C2 for SLPS, SLAS anchors

Essential characteristics for seismic performance category C2			Performances	
			M12 Ø18	
Resistance to steel failure under tension loads				
N _{Rk,s,C2}	Characteristic tension steel failure:	[kN]	67.4	
γ _{Ms}	Partial safety factor: ¹⁾	[-]	1.5	
Resistance to steel failure under shear loads				
V _{Rk,s,C2}	Characteristic shear steel failure:	[kN]	29.9	
γ _{Ms}	Partial safety factor: ¹⁾	[-]	1.25	
Resistance to pull-out failure				
N _{Rk,p,C2}	Characteristic pull out failure:	[kN]	12.6	
γ _{inst}	Robustness:	[-]	1.0	
Resistance to concrete cone failure				
h _{ef}	Effective embedment depth:	[mm]	85	
s _{cr,N}	Spacing:	[mm]	3 x h _{ef}	
c _{cr,N}	Edge distance:	[mm]	1.5 x h _{ef}	
γ _{inst}	Robustness:	[-]	1.0	
Displacements				
Δ _{N,C2(0.5)}	Displacement Damage Limitation State:	[mm]	5.9	
Δ _{V,C2(0.5)}		[mm]	5.8	
Δ _{N,C2(0.8)}	Displacement Ultimate Limit State:	[mm]	19.0	
Δ _{V,C2(0.8)}		[mm]	9.4	

¹⁾ In absence of other national regulations

SLPT anchor	Annex C8
Performances	
Essential characteristics for C2 seismic performances	



Table C15: Characteristic values for resistance under fire exposure for SLPT, SLAT, SLPC, SLAC, SLPE, SLAE anchors

Characteristic values under fire exposure				Performances					
				M6 Ø10	M8 Ø12	M10 Ø16	M12 Ø18	M16 Ø24	M20 Ø28
Fire resistance to steel failure									
N _{Rk,s,fi}	Characteristic tension resistance:	R30	[kN]	0.2	0.4	0.9	1.7	3.1	4.9
		R60	[kN]	0.2	0.3	0.8	1.3	2.4	3.7
		R90	[kN]	0.1	0.3	0.6	1.1	2.0	3.2
		R120	[kN]	0.1	0.2	0.5	0.8	1.6	2.5
V _{Rk,s,fi}	Characteristic shear resistance:	R30	[kN]	0.2	0.4	0.9	1.7	3.1	4.9
		R60	[kN]	0.2	0.3	0.8	1.3	2.4	3.7
		R90	[kN]	0.1	0.3	0.6	1.1	2.0	3.2
		R120	[kN]	0.1	0.2	0.5	0.8	1.6	2.5
M ⁰ _{Rk,s,fi}	Characteristic bending resistance:	R30	[Nm]	0.2	0.4	1.1	2.6	6.7	13.0
		R60	[Nm]	0.1	0.3	1.0	2.0	5.0	9.7
		R90	[Nm]	0.1	0.3	0.7	1.7	4.3	8.4
		R120	[Nm]	0.1	0.2	0.6	1.3	3.3	6.5
Fire resistance to pull-out failure									
N _{Rk,p,fi}	Characteristic resistance:	R30 to R90	[kN]	3.0	4.8	7.1	11.5	17.2	30.1
		R120	[kN]	2.4	3.8	5.6	9.2	13.8	24.1
Fire resistance to concrete cone failure ¹⁾									
N _{Rk,c,fi}	Characteristic resistance:	R30 R60 R90	[kN]	3.0	4.8	7.1	11.5	17.2	30.1
		R120	[kN]	2.4	3.8	5.6	9.2	13.8	24.1
S _{cr,N,fi}	Spacing:	R30 to R120	[mm]	4 x h _{ef}					
C _{cr,N,fi}	Edge distance:	R30 to R120	[mm]	2 x h _{ef}					
S _{min,fi}	Minimum spacing:	R30 to R120	[mm]	100	120	175	200	220	320
C _{min,fi}	Minimum edge distance:	R30 to R120	[mm]	C _{min} = 2 x h _{ef} ; if fire attack comes from more than one side, the edge distance of the anchor has to be ≥ 300 mm and ≥ 2 x h _{ef}					
Fire resistance to concrete pry-out failure									
k ₈	Pryout factor:	R30 to R120	[-]	3.2	3.0	3.4	3.6	4.3	4.3

- 1) As a rule, splitting failure can be neglected since cracked concrete and reinforcement is assumed.
- 2) In absence of other national regulations the partial safety factor for resistance under fire exposure $\gamma_{m,fi} = 1,0$ is recommended

SLPT anchor	Annex C9
Performances	
Characteristic values under fire exposure	



Table C16: Characteristic values for resistance under fire exposure for SLPS, SLAS anchors

Characteristic values under fire exposure				Performances	
				M12 Ø18	
Fire resistance to steel failure					
N _{Rk,s,fi}	Characteristic tension resistance:	R30	[kN]	1.7	
		R60	[kN]	1.3	
		R90	[kN]	1.1	
		R120	[kN]	0.8	
V _{Rk,s,fi}	Characteristic shear resistance:	R30	[kN]	1.7	
		R60	[kN]	1.3	
		R90	[kN]	1.1	
		R120	[kN]	0.8	
M ⁰ _{Rk,s,fi}	Characteristic bending resistance:	R30	[Nm]	2.6	
		R60	[Nm]	2.0	
		R90	[Nm]	1.7	
		R120	[Nm]	1.3	
Fire resistance to pull-out failure					
N _{Rk,p,fi}	Characteristic resistance:	R30 to R90	[kN]	6.6	
		R120	[kN]	5.3	
Fire resistance to concrete cone failure ¹⁾					
N _{Rk,c,fi}	Characteristic resistance:	R30 R60 R90	[kN]	6.56	
		R120	[kN]	5.25	
S _{cr,N,fi}	Spacing:	R30 to R120	[mm]	4 x h _{ef}	
C _{cr,N,fi}	Edge distance:	R30 to R120	[mm]	2 x h _{ef}	
S _{min,fi}	Minimum spacing:	R30 to R120	[mm]	205	
C _{min,fi}	Minimum edge distance:	R30 to R120	[mm]	C _{min} = 2 x h _{ef} ; if fire attack comes from more than one side, the edge distance of the anchor has to be ≥ 300 mm and ≥ 2 x h _{ef}	
Fire resistance to concrete pry-out failure					
k _s	Pryout factor:	R30 to R120	[-]	2.0	

- 1) As a rule, splitting failure can be neglected since cracked concrete and reinforcement is assumed.
- 2) In absence of other national regulations the partial safety factor for resistance under fire exposure $\gamma_{m,fi} = 1,0$ is recommended

SLPT anchor	Annex C10
Performances	
Characteristic values under fire exposure	

