



**INSTITUTO DE CIENCIAS
DE LA CONSTRUCCIÓN
EDUARDO TORROJA**

C/ Serrano Galvache n. 4 28033 Madrid (Spain)
Tel.: (34) 91 302 04 40 Fax: (34) 91 302 07 00
direccion.ietcc@csic.es www.ietcc.csic.es

European Technical Assessment

**ETA-14/0135
of 11/05/2026**

English translation prepared by IETcc. Original version in Spanish language

General Part

Technical Assessment Body issuing the European Technical Assessment:
Instituto de Ciencias de la Construcción Eduardo Torroja (IETcc)

**Trade name of the construction
product**

HEHO / HECLO drop in anchor
Deformation controlled anchor made of galvanized steel of sizes M6, M8, M10, M12, M16 and M20 for use in non-cracked concrete

**Product family to which the
construction product belongs**

FIXINGS
Product Area Code (PAC): 33

Manufacturer

Index - Técnicas Expansivas S.L.
Segador 13
26006 Logroño (La Rioja) Spain.
website: www.indexfix.com

Manufacturing plant

Index plant 2

**This European Technical
Assessment contains**

9 pages,
including annexes 1-3, which form an integral part of this assessment.
+ Annex 4. Contain confidential information and is not included in the ETA when that assessment is publicly available

**This European Technical
Assessment is issued in accordance
with Article 95(4) of Regulation (EU)
2024/3110, on the basis of**

EAD 330232-02-0601:
"Mechanical Fasteners for use in concrete",
ed. September 2024

This version replaces

ETA 14/0135 version 3 issued on 10/06/2021

Translations of this European Technical Assessment in other languages shall fully correspond to the original issued document and shall be identified as such.

Communication of this European Technical Assessment, including transmission by electronic means, shall be in full (excepted confidential(s) Annex(es) referred to above. However, partial reproduction may be made, with the written consent of the issuing Technical Assessment Body. Any partial reproduction must be identified as such



SPECIFIC PART

1. Technical description of the product

The Index HEHO / HECLO in the range of M6 to M20 is an anchor made of galvanised steel, which is placed into a drilled hole and anchored by deformation-controlled expansion. The anchorage is characterised by friction between the sleeve and concrete.

Product and product description is given in annex A.

2. Specification of the intended use in accordance with the applicable European Assessment Document

2.1 Intended use

The performances given in section 3 are only valid if the anchor is used in compliance with the specifications and conditions given in annex B.

2.2 Relevant general conditions for the use of the product

The verifications and assessment methods on which this European Technical Assessment is based lead to the assumption of a working life of the anchor of at least 50 years. The indications given on the working life cannot be interpreted as a guarantee given by the producer, but are to be regarded only as a mean to choosing the right products in relation to the expected economically reasonable working life of the works.

3. Performance of the product and references to the methods used for its assessment

3.1 Mechanical resistance and stability (BWR 1)

Essential characteristic	Relevant clause in EAD	Performance	Annex
Resistance to steel failure under tension load	2.2.1	$N_{Rk,s}$ [kN]	C2
Resistance to pull-out failure	2.2.2	$N_{Rk,p,ucr}$ [kN], $N_{Rk,p,cr}$ [kN], $\psi_{c,cr}$ [-], $\psi_{c,ucr}$ [-]	C2
Resistance to concrete cone failure	2.2.3	$k_{cr,N}$ [-], $k_{ucr,N}$ [-], h_{ef} [mm], $c_{cr,N}$ [mm]	C2
Robustness	2.2.4	γ_{inst} [-]	C2
Minimum edge distance and spacing	2.2.5	c_{min} [mm], s_{min} [mm], h_{min} [mm]	C2
Edge distance to prevent splitting under load	2.2.6	$N_{Rk,sp}^0$ [kN], $c_{cr,sp}$ [mm]	C2
Resistance to steel failure under shear load	2.2.7	$V_{Rk,s}^0$ [kN], $M_{Rk,s}^0$ [Nm], k_7 [-]	C3
Resistance to pry-out failure	2.2.8	k_8 [-]	C3
Displacement under static and quasi-static loading	2.2.10	δ_{NO} [mm], $\delta_{N\infty}$ 50 years [mm], δ_{V0} [mm], $\delta_{V\infty}$ [mm]	C3
Stiffness in the elastic range under tension loading	2.2.11.1	$K_{A,ucr}$, $K_{A,ce}$ [Nm]	NPD
Stiffness characteristics for tension loading for non-linear spring models	2.2.11.2	$K_{A,ucr}$, $K_{B,ucr}$, $K_{C,ucr}$, $K_{D,ucr}$ [N/mm] $K_{A,cr}$, $K_{B,cr}$, $K_{C,cr}$ and $K_{D,cr}$ [N/mm]	NPD
Resistance to tension load for seismic performances category C1	2.2.12	$N_{Rk,s,C1}$, $N_{Rk,p,C1}$ [N]	NPD
Resistance to shear load for seismic performances category C1, factor for annular gap	2.2.13	$V_{Rk,s,C1}$ [N]	NPD
Resistance to tension load and displacements for seismic performances category C2	2.2.14	$N_{Rk,s,C2}$, $N_{Rk,p,C2}$ [N] $\delta_{v,C2(0,5)}$, $\delta_{v,C2(0,8)}$ [mm]	NPD
Resistance to shear load and displacements for seismic performances category C2, factor for annular gap	2.2.15	$V_{Rk,s,C2}$ [N] $\delta_{v,C2(0,5)}$, $\delta_{v,C2(0,8)}$ [mm]	NPD



3.2 Safety in case of fire (BWR 2)

Essential characteristic	Relevant clause in EAD	Performance	Annex
Reaction to fire	2.2.16	Anchorage satisfy requirements for class A1 according to EN 13501-1	--
Fire resistance to steel failure, tension load	2.2.17	$N_{Rk,s,fi}$ [N]	NPD
Fire resistance to pull out failure, tension load	2.2.18	$N_{Rk,p,fi}$ [N]	NPD
Fire resistance to steel failure, shear load	2.2.19	$V_{Rk,s,fi}$ [N], $M^0_{Rk,s,fi}$	NPD

3.3 Durability

Essential characteristic	Relevant clause in EAD	Performance	Annex
Durability	2.2.20	Coated in zinc plated	A2

4. Assessment and Verification of Constancy of Performances (hereinafter AVCP) system applied, with reference to its legal base

The applicable European legal act for the system of Assessment and Verification of Constancy of Performances (see annex V to Regulation (EU) No 305/2011) is 96/582/EC.

The system to be applied is 1.

5. Technical details necessary for the implementation of the AVCP system, as provided for in the applicable European Assessment Document

Technical details necessary for the implementation of the AVCP system are laid down in the control plan which is deposited at IETcc⁽¹⁾.

For type testing, the results of the tests performed as part of the assessment for the European Technical Assessment shall be used unless there are changes in the production line or plant. In such cases, the necessary type testing has to be agreed between IETcc and the notified body.

Prepared by: PhD Julián Rivera (Innovative Products Assessment Unit, IETcc-CSIC)

Issued in Madrid on 2026 may 11

Director

on behalf of Instituto de Ciencias de la Construcción Eduardo Torroja (IETcc – CSIC)

⁽¹⁾ The Quality Plan is a confidential part of the ETA and only handed over to the notified certification body involved in the assessment and verification of constancy of performance.



Product

HEHO, HECLO anchor



HEHO anchor

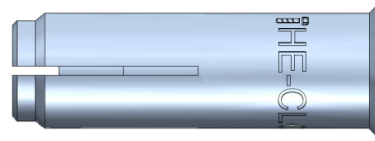

HECLO anchor

Identification on sleeve: Index logo + “HEHO (HECLO)” + Metric; e.g:  HEHO M6

Anchor dimensions		M6	M8	M10	M12	M16	M20
ØD: External diameter	[mm]	8	10	12	15	20	25
Ød: internal diameter	[mm]	M6	M8	M10	M12	M16	M20
L: total length	[mm]	25	30	40	50	65	80

Setting tool



Setting tool dimensions		M6	M8	M10	M12	M16	M20
Ø D ₁	[mm]	8.0	10.0	12.0	15.0	20.0	25.0
Ø D ₂	[mm]	4.9	6.4	8.2	10.0	13.5	17.0
L _s	[mm]	15.0	18.0	21.0	30.0	36.0	40.0

M20 Setting tool has no plastic handle

HEHO, HECLO anchor	Annex A1
Product description	
Product	



Installed condition

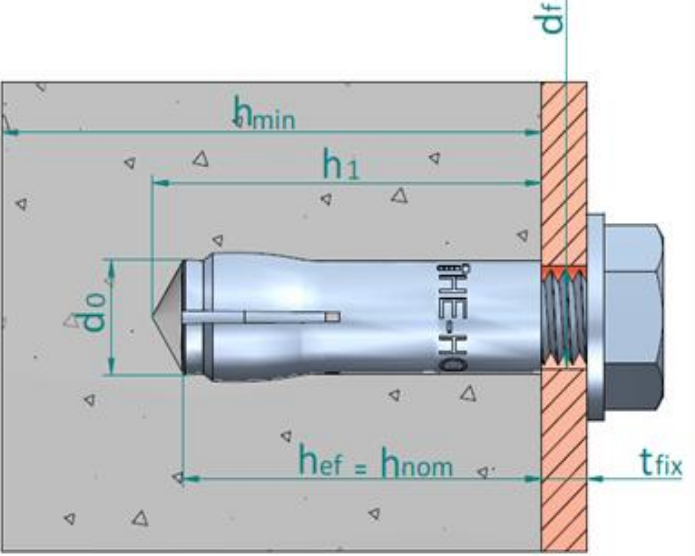

h_{ef} : Effective anchorage depth
 h_1 : Depth of drilled hole
 h_{nom} : Overall anchor embedment depth in the concrete
 h_{min} : Minimum thickness of concrete member
 t_{fix} : Thickness of fixture
 d_0 : Nominal diameter of drill bit
 d_f : Fixture clearance hole diameter

Table A1: materials

Item	Designation	Material for HEHO / HECLO
1	Sleeve	Carbon steel wire rod, zinc plated $\geq 5 \mu\text{m}$ ISO 4042 A2
2	Cone	Carbon steel wire rod, zinc plated $\geq 5 \mu\text{m}$ ISO 4042 A2
3	Plastic retainer	PVC

HEHO, HECLO anchor	Annex A2
Product description	
Installed condition and materials	



<p>Specifications of intended use</p> <p>Anchorage subjected to:</p> <ul style="list-style-type: none"> • Static or quasi static loads <p>Base materials:</p> <ul style="list-style-type: none"> • Reinforced or unreinforced normal weight concrete without fibres according to EN 206:2013+A1:2016 • Strength classes C20/25 to C50/60 according to EN 206:2013+A1:2016 • Uncracked concrete <p>Use conditions (environmental conditions):</p> <ul style="list-style-type: none"> • Anchorages subjected to dry internal conditions. <p>Design:</p> <ul style="list-style-type: none"> • Anchorages are designed under the responsibility of an engineer experienced in anchorages and concrete. • Verifiable calculation rules and drawings are prepared taking into account of the loads to be anchored. The position of the anchor is indicated on the design drawings (e.g. position of the anchor relative to reinforcement or to supports, etc.). • Anchorages under static or quasi-static actions are designed for design method A in accordance with EN 1992-4:2018 <p>Installation:</p> <ul style="list-style-type: none"> • Hole drilling by rotary plus hammer mode. • Anchor installation carried out by appropriately qualified personal and under the supervision of the person responsible for technical matters of the site. • In case of aborted hole: new drilling at a minimum distance away of twice the depth of aborted hole or smaller distance if the aborted hole is filled with high strength mortar and if under shear or oblique tension load it is not the direction of the load application. • The bolt or threaded rod to be used shall be property class 4.6 / 4.8 / 5.6 / 5.8 / 6.8 or 8.8 according to ISO 898-1. • The length of the bolt shall be determined as: <ul style="list-style-type: none"> ○ Minimum bolt length = $t_{fix} + l_{s,min}$ ○ Maximum bolt length = $t_{fix} + l_{s,max}$ 	
HEHO, HECLO anchor	Annex B1
Intended use	
Specifications	



Table C1: Installation parameters for HEHO, HECLO anchor

Installation parameters			Performances					
			M6	M8	M10	M12	M16	M20
d_o	Nominal diameter of drill bit:	[mm]	8	10	12	15	20	25
D	Thread diameter:	[mm]	M6	M8	M10	M12	M16	M20
d_f	Fixture clearance hole diameter \leq	[mm]	7	9	12	14	18	22
T_{inst}	Maximum installation torque:	[Nm]	4	11	17	38	60	100
$l_{s,min}$	Minimum screwing depth:	[mm]	6	8	10	12	16	20
$l_{s,max}$	Maximum screwing depth:	[mm]	10	13	17	21	27	34
h_{min}	Minimum thickness of concrete member:	[mm]	100	100	100	100	130	160
h_1	Depth of drilled hole:	[mm]	27	33	43	54	70	86
h_{nom}	Overall anchor embedm. depth in the concrete:	[mm]	25	30	40	50	65	80
h_{ef}	Effective anchorage depth:	[mm]	25	30	40	50	65	80
s_{min}	Minimum allowable spacing:	[mm]	60	60	80	100	130	160
c_{min}	Minimum allowable distance:	[mm]	105	105	140	175	230	280

Installation process

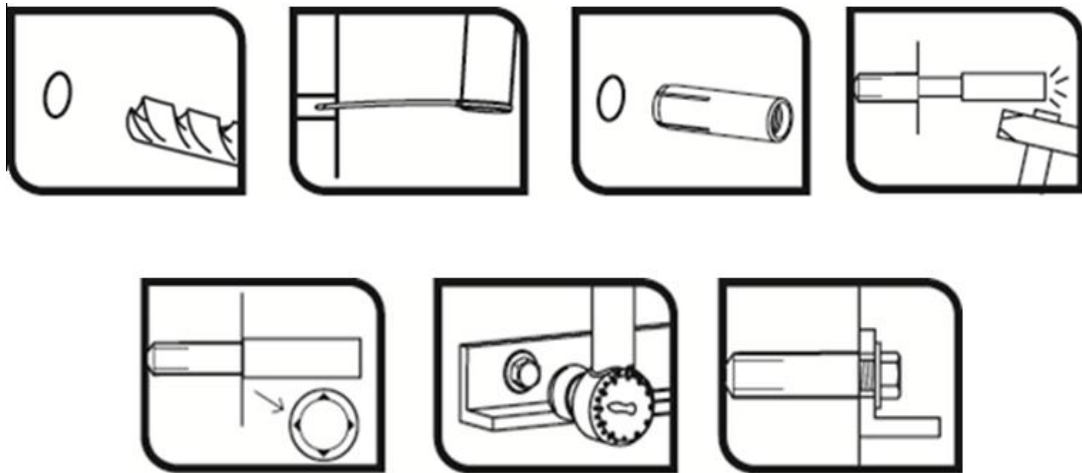

HEHO, HECLO anchor	Annex C1
Performances	
Installation parameters and installation procedure	



Table C2: Characteristic values to tension loads of design method A according to EN 1992-4 for HEHO, HECLO anchor

Characteristic values of resistance to tension loads of design according to design method A			Performances						
			M6	M8	M10	M12	M16	M20	
Tension loads: steel failure									
$N_{Rk,s}$	Tension steel char. resistance, steel class 4.6:	[kN]	8,0	14,6	23,2	33,7	62,8	98,0	
$\gamma_{Ms}^{1)}$	Partial safety factor:	[-]	2,0	2,0	2,0	2,0	2,0	2,0	
$N_{Rk,s}$	Tension steel char. resistance, steel class 4.8:	[kN]	8,0	14,6	18,2	33,7	62,8	95,1	
$\gamma_{Ms}^{1)}$	Partial safety factor:	[-]	1,5	1,5	1,5	1,5	1,5	1,5	
$N_{Rk,s}$	Tension steel char. resistance, steel class 5.6:	[kN]	10,1	18,3	18,2	42,2	78,5	122,5	
$\gamma_{Ms}^{1)}$	Partial safety factor:	[-]	2,0	2,0	1,5	2,0	2,0	2,0	
$N_{Rk,s}$	Tension steel char. resistance, steel class 5.8:	[kN]	10,1	17,6	18,2	35,1	65,0	95,1	
$\gamma_{Ms}^{1)}$	Partial safety factor:	[-]	1,5	1,5	1,5	1,5	1,5	1,5	
$N_{Rk,s}$	Tension steel char. resistance, steel class 6.8	[kN]	12,1	17,6	18,2	35,1	65,0	95,1	
$\gamma_{Ms}^{1)}$	Partial safety factor:	[-]	1,5	1,5	1,5	1,5	1,5	1,5	
$N_{Rk,s}$	Tension steel char. resistance, steel class 8.8	[kN]	13,1	17,6	18,2	35,1	65,0	95,1	
$\gamma_{Ms}^{1)}$	Partial safety factor:	[-]	1,5	1,5	1,5	1,5	1,5	1,5	
Tension loads: pull-out failure in concrete									
$N_{Rk,p,ucr}$	Tension characteristic resistance in C20/25 uncracked concrete	[kN]	-- 2)	-- 2)	-- 2)	-- 2)	-- 2)	-- 2)	
ψ_c	Increasing factor for $N_{Rk,p}^0$:	C30/37	[-]	1,02	1,22	1,15	1,15	1,22	1,19
		C40/50	[-]	1,04	1,41	1,29	1,28	1,41	1,35
		C50/60	[-]	1,05	1,55	1,37	1,37	1,55	1,46
γ_{inst}	Installation safety factor:	[-]	1,2	1,2	1,4	1,4	1,4	1,4	
Tension loads: concrete cone and splitting failure									
h_{ef}	Effective embedment depth:	[mm]	25	30	40	50	65	80	
$k_{ucr,N}$	Factor for uncracked concrete:	[-]	11,0						
γ_{ins}	Installation safety factor:	[-]	1,2	1,2	1,4	1,4	1,4	1,4	
$s_{cr,N}$	Concrete cone failure:	[mm]	3 x h_{ef}						
$c_{cr,N}$		[mm]	1,5 x h_{ef}						
$s_{cr,sp}$	Splitting failure:	[mm]	150	180	240	300	390	480	
$c_{cr,sp}$		[mm]	75	90	120	150	195	240	
Displacements under tension loads									
N	Service tension load in uncracked concrete C20/25 to C50/60:	[kN]	2,4	3,4	6,0	7,4	17,8	18,2	
δ_{N0}	Short term displacement under tension loads:	[mm]	0,1	0,1	0,1	0,1	0,1	0,1	
$\delta_{N\infty}$	Long term displacement under tension loads:	[mm]	0,3	0,3	0,3	0,3	0,3	0,3	

¹⁾ In absence of other national regulations
²⁾ Pull out failure does not govern

HEHO, HECLO anchor	Annex C2
Performances	
Characteristic values for tension loads	



Table C3: Characteristic values to shear loads of design method A according to EN1992-4 for HEHO, HECLO anchor

Characteristic values of resistance to shear loads of design according to design method A			Performances					
			M6	M8	M10	M12	M16	M20
Shear loads: steel failure without lever arm								
$V_{Rk,s}$	Shear steel char. resistance, steel class 4.6:	[kN]	4,0	7,3	11,6	16,8	31,4	49,0
$\gamma_{Ms}^{(1)}$	Partial safety factor:	[-]	1,67	1,67	1,67	1,67	1,67	1,67
$V_{Rk,s}$	Shear steel char. resistance, steel class 4.8:	[kN]	4,0	7,3	9,1	16,8	31,4	47,5
$\gamma_{Ms}^{(1)}$	Partial safety factor:	[-]	1,25	1,25	1,25	1,25	1,25	1,25
$V_{Rk,s}$	Shear steel char. resistance, steel class 5.6	[kN]	5,0	9,1	9,1	21,1	39,2	61,2
$\gamma_{Ms}^{(1)}$	Partial safety factor:	[-]	1,67	1,67	1,25	1,67	1,67	1,67
$V_{Rk,s}$	Shear steel char. resistance, steel class 5.8	[kN]	5,0	8,8	9,1	17,5	32,5	47,5
$\gamma_{Ms}^{(1)}$	Partial safety factor:	[-]	1,25	1,25	1,25	1,25	1,25	1,25
$V_{Rk,s}$	Shear steel char. resistance, steel class 6.8	[kN]	6,0	8,8	9,1	17,5	32,5	47,5
$\gamma_{Ms}^{(1)}$	Partial safety factor:	[-]	1,25	1,25	1,25	1,25	1,25	1,25
$V_{Rk,s}$	Shear steel char. resistance, steel class 8.8:	[kN]	6,5	8,8	9,1	17,5	32,5	47,5
$\gamma_{Ms}^{(1)}$	Partial safety factor:	[-]	1,25	1,25	1,25	1,25	1,25	1,25
Shear loads: steel failure with lever arm								
$M_{Rk,s}^0$	Characteristic bending moment, steel class 4.6	[Nm]	6,1	15,0	29,9	52,4	133,3	259,8
$\gamma_{Ms}^{(1)}$	Partial safety factor:	[-]	1,67	1,67	1,67	1,67	1,67	1,67
$M_{Rk,s}^0$	Characteristic bending moment, steel class 4.8	[Nm]	6,1	15,0	29,9	52,4	133,3	259,8
$\gamma_{Ms}^{(1)}$	Partial safety factor:	[-]	1,25	1,25	1,25	1,25	1,25	1,25
$M_{Rk,s}^0$	Characteristic bending moment, steel class 5.6	[Nm]	7,6	18,8	37,4	65,5	166,6	324,8
$\gamma_{Ms}^{(1)}$	Partial safety factor:	[-]	1,67	1,67	1,67	1,67	1,67	1,67
$M_{Rk,s}^0$	Characteristic bending moment, steel class 5.8	[Nm]	7,6	18,8	37,4	65,5	166,6	324,8
$\gamma_{Ms}^{(1)}$	Partial safety factor:	[-]	1,25	1,25	1,25	1,25	1,25	1,25
$M_{Rk,s}^0$	Characteristic bending moment, steel class 6.8	[Nm]	9,2	22,5	44,9	78,7	199,9	389,7
$\gamma_{Ms}^{(1)}$	Partial safety factor:	[-]	1,25	1,25	1,25	1,25	1,25	1,25
$M_{Rk,s}^0$	Characteristic bending moment, steel class 8.8	[Nm]	12,2	30,0	59,9	104,9	266,6	519,7
$\gamma_{Ms}^{(1)}$	Partial safety factor:	[-]	1,25	1,25	1,25	1,25	1,25	1,25
Shear loads: concrete pryout failure								
k_8	Pryout factor:	[-]	1,0	1,0	1,0	1,0	2,0	2,0
γ_{inst}	Installation safety factor:	[-]	1,0					
Shear loads: concrete edge failure								
l_f	Effective anchorage depth under shear loads:	[mm]	25	30	40	50	65	80
d_{nom}	Outside anchor diameter:	[mm]	8	10	12	15	20	25
γ_{inst}	Installation safety factor:	[-]	1,0					
Displacements under shear loads								
V	Service shear load in uncracked concrete C20/25 to C50/60:	[kN]	3,8	5,0	5,2	10,1	18,6	27,2
δ_{V0}	Short term displacement under shear loads:	[mm]	2,4	2,4	2,4	1,3	1,0	1,0
$\delta_{V\infty}$	Long term displacement under shear loads:	[mm]	3,5	3,5	3,5	2,0	1,5	1,5

¹⁾ In absence of other national regulations

HEHO, HECLO anchor	Annex C3
Performances	
Characteristic values for shear loads	

