



EV-HA4



EV-MA4



GR-A4



GI-A4



GD-A4



SJ-A4



SJ-PSA4



SJ-PDA4



TS-GAA4



TS-AAA4











TS-GGA4

**CHARACTERISTICS**

- Accessories for cables and chains
- Made of A4 stainless steel
- Forged steel elements
- For securing large loads
- Use: for securing, fixing and protecting cables, etc.

**BASE MATERIAL**



1. RANGE				
ITEM	CODE	TYPE	PHOTO	MATERIAL
1	EV-HA4	582		
2	EV-MA4	580		
3	GR-A4	82101		
4	GI-A4	----		
5	GD-A4	6899A		
6	SJ-A4	741		
7	SJ-PSA4	---		
8	SJ-PDA4	---		
9	TS-GAA4	1480		
10	TS-AAA4	1480		
11	TS-GGA4	1480		

## 2. INSTALLATION DATA

### 2.1 EV-HA4

#### Female eyebolt D-582, A4 Stainless Steel



#### Material



A4 Stainless Steel

#### Base material



Cable



Chain



Rope

#### Installation Data

CODE	CABLE Ø	M	D1 [mm]	D2 [mm]	L1 [mm]	H1 [mm]	Axial load capacity per ring (WLL)	Load capacity per ring (WLL) 0° < β ≤ 45°	Load capacity per ring (WLL)	
									0° < β ≤ 45°	0° < β ≤ 45°
EVHA406	18	M6	15	16	27	27	75	55	38	
EVHA408	20	M8	20	20	36	36	140	100	70	
EVHA410	25	M10	25	25	45	45	230	170	115	
EVHA412	30	M12	30	30	52	51	340	240	170	
EVHA414	35	M14	30	30	54	53	490	350	245	
EVHA416	35	M16	35	35	63	62	700	500	350	
EVHA420	40	M20	38	40	70	68	1200	860	600	
EVHA424	50	M24	50	50	90	90	1800	1290	900	

#### CHARACTERISTICS

- Eyebolt type 582
- A4 Stainless Steel
- Female thread
- Easy installation
- For parts whose attachment point presents a male thread
- Not valid for use as personal protective equipment (PPE)

#### DRAWING

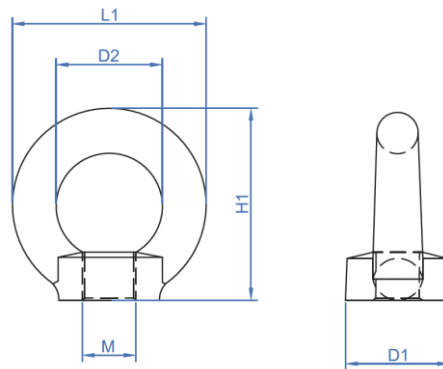

<b>2.2 EV-MA4</b> 	<b>Male eyebolt D-580, A4 Stainless Steel</b>			
	<b>Material</b>		<b>Base material</b>	
	 A4 Stainless Steel		 Cable	 Chain

<b>Installation Data</b>										
CODE	CABLE Ø	M	D1 [mm]	D2 [mm]	L1 [mm]	H1 [mm]	Axial load capacity per ring (WLL)	Load capacity per ring (WLL) 0° < β ≤ 45°	Load capacity per ring (WLL)	
									0° < β ≤ 45°	0° < β ≤ 45°
EVHA406	20	M6	15	15	27	27	75	55	38	
EVHA408	20	M8	20	20	36	36	140	100	70	
EVHA410	25	M10	25	25	45	45	230	170	115	
EVHA412	30	M12	30	30	54	53	340	240	170	
EVHA414	35	M14	30	30	54	53	490	350	245	
EVHA416	35	M16	35	35	63	62	700	500	350	
EVHA420	40	M20	40	40	72	71	1200	860	600	
EVHA424	50	M24	50	49	90	90	1800	1290	900	

- CHARACTERISTICS**
- Eyebolt type 582
  - A4 Stainless Steel
  - Male thread
  - Easy installation
  - For parts whose attachment point presents a male thread
  - Not valid for use as personal protective equipment (PPE)

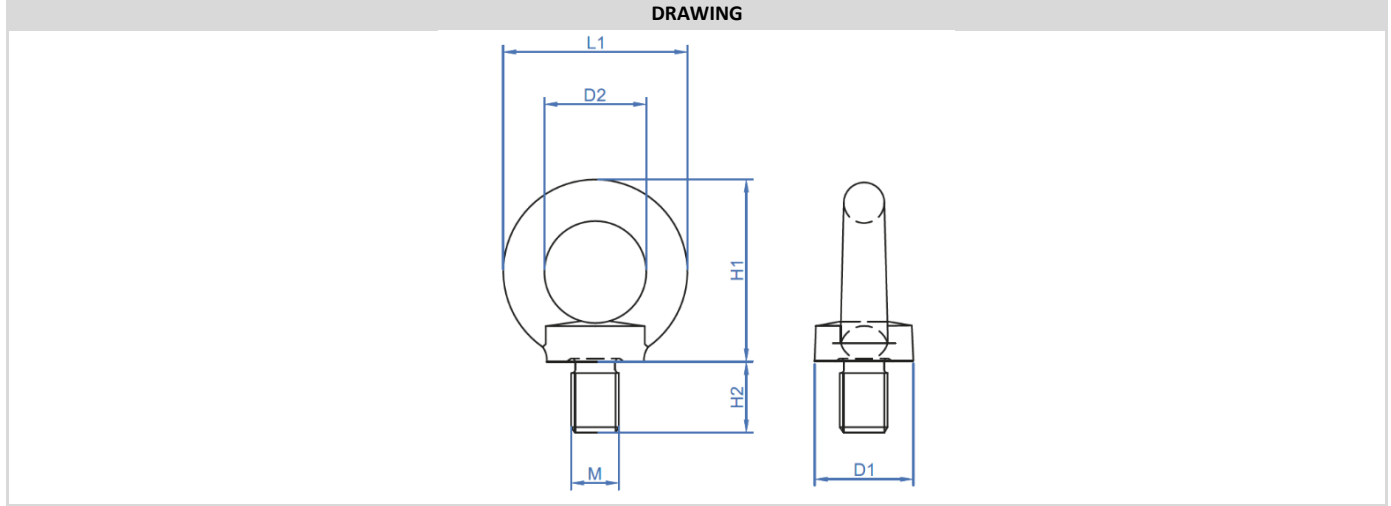

**2.3 GR-A4**

**Straight Shackle, A4 Stainless Steel**



**Material**



A4 Stainless Steel

**Base material**



Cable



Chain



Rope

**Installation Data**

CODE	CABLE Ø [mm]	M	A [mm]	B [mm]	ØD [mm]	d [mm]	C [mm]	(WLL) Axial load capacity in kg
GRA404	8	M4	10	11	4	4	19	70
GRA405	10	M5	10	11	5	5	19	100
GRA406	12	M6	13	11	6	6	25	160
GRA408	16	M8	16	18	8	8	32	250
GRA410	19	M10	19	20	10	10	38	400
GRA412	25	M12	25	26	12	12	51	600
GRA414	28	M14	29	26	14	14	55	750
GRA416	32	M16	32	33	16	16	64	1000
GRA419	38	M19	38	40	19	19	76	1600
GRA425	50	M25	51	57	25	25	100	2000

**CHARACTERISTICS**

- Straight shackle type 82101
- A4 Stainless Steel
- Easy installation
- Fastening element to use with rings and other items
- For correct use, the bolt must always be attached to the straight pin, while the cable must pull from the shackle bow
- High quality finish
- Not valid for use as personal protective equipment (PPE)

**DRAWING**

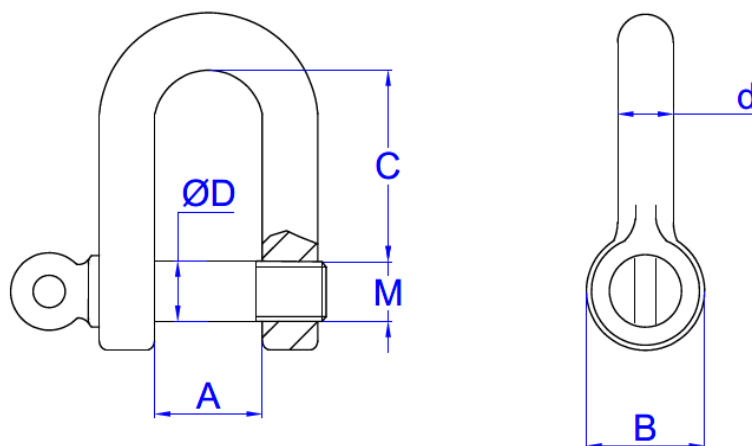

2.4 GI-A4

Bow Shackle, A4 Stainless Steel



Material



A4 Stainless Steel

Base material



Cable



Chain



Rope

Installation Data

CODE	CABLE Ø [mm]	M	A [mm]	b [mm]	ØD [mm]	L1 [mm]	L2 [mm]	H1 [mm]	(WLL) Axial load capacity in kg
GIA404	8	M5	10	11	5	5	11	20	100
GIA405	10	M6	12	11	6	6	14	24	160
GIA406	12	M8	16	14	8	8	18	32	250
GIA408	16	M10	20	18	10	10	20	40	400
GIA410	19	M11	22	20	11	12	26	44	470
GIA412	25	M12	24	33	12	16	33	48	600
GIA414	28	M14	28	40	24	20	40	56	750
GIA416	32	M16	32	50	26	22	50	64	1000

DRAWING

- Easy installation
- A4 Stainless Steel
- Fastening element to use with rings and other items
- For correct use, the bolt must always be attached to the straight pin, while the cable must pull from the shackle bow
- High quality finish
- Not valid for use as personal protective equipment (PPE)

CHARACTERISTICS

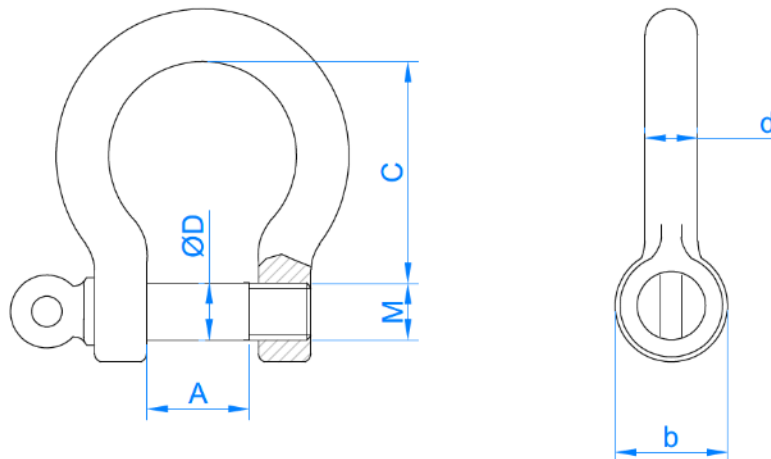

2.5 GD-A4

Thimble, A4 Stainless Steel



Material

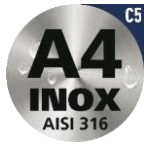

A4 Stainless Steel

Base material



Cable



Chain



Rope

Installation Data

CODE	CABLE Ø [mm]	A [mm]	B [mm]	L1 [mm]	L2 [mm]	Characteristics
GDA402	2	12	19	3,0	1,5	<ul style="list-style-type: none"> <li>- Thimble conforming DIN 6899A</li> <li>- Stainless steel A4</li> <li>- Easy installation</li> <li>- Element to ensure cable protection against friction</li> <li>- High quality finish</li> </ul>
GDA403	3	13	21	3,5	1,5	
GDA404	4	14	23	5,0	2,0	
GDA405	5	16	25	6,0	2,5	
GDA406	6	18	28	7,0	2,5	
GDA408	8	24	37	9,0	3,0	
GDA410	10	28	45	11,0	3,5	
GDA412	12	30	48	13,0	3,5	
GDA415	15	36	58	16,0	3,5	

DRAWING

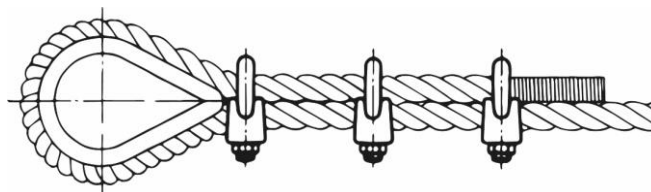
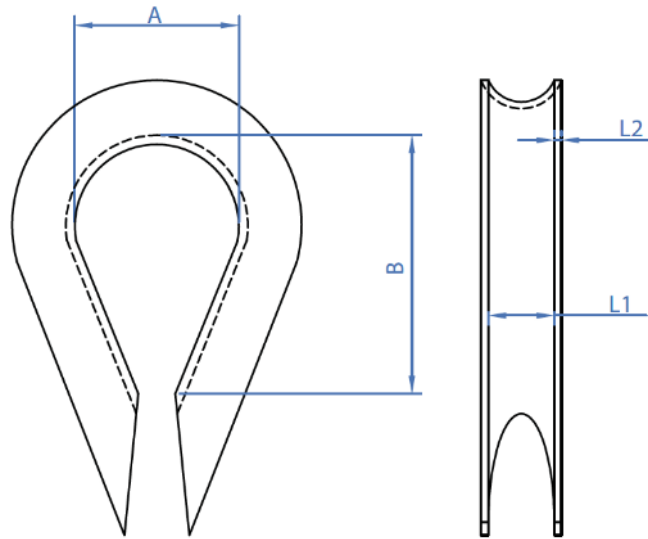

2.6 SJ-A4

Wire rope clip A4, Stainless Steel



Material



A4 Stainless Steel

Base material



Cable

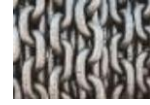

Chain



Rope

Installation Data

CODE	CABLE Ø	M	A	B	ØD	H1	H2	L1	L2	Sw	Characteristics
SJA42103	3	M4	9	12	4	20	10	21	10	6.78 ÷ 7	<ul style="list-style-type: none"> <li>- Wire rope clip type 741</li> <li>- Easy installation</li> <li>- Cable fixing element in conjunction with thimbles and others</li> <li>- For correct use of the wire rope clip, the distance between fixings must be between 1.5 and 3 times the width of L2.</li> <li>- High quality finish.</li> </ul>
SJA42305	5	M5	11	13	6	24	10	23	11	7.78 ÷ 8	
SJA42606	6	M5	13	15	8	28	11	26	12		
SJA43008	8	M6	16	19	9	34	15	30	14	9.78 ÷ 10	
SJA43410	10	M8	19	22	11	42	17	34	18	12.73 ÷ 13	
SJA43611	11	M8	20	22	12	44	18	36	19		
SJA44414	14	M10	24	30	15	56	22	44	23	16.73 ÷ 17	
SJA45016	16	M12	29	33	17	63	26	50	26	18.67 ÷ 19	
SJA45418	18	M12	30	37	21	75	29	53	28		
SJA46122	22	M14	38	44	23	85	34	61	33	21.67 ÷ 22	
SJA46525	25	M14	42	45	27	95	37	65	35		

DRAWING

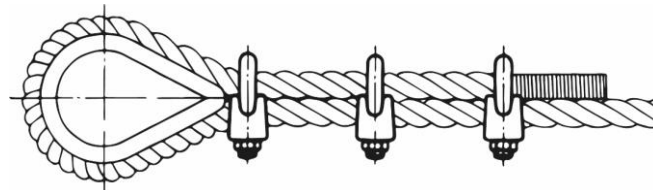
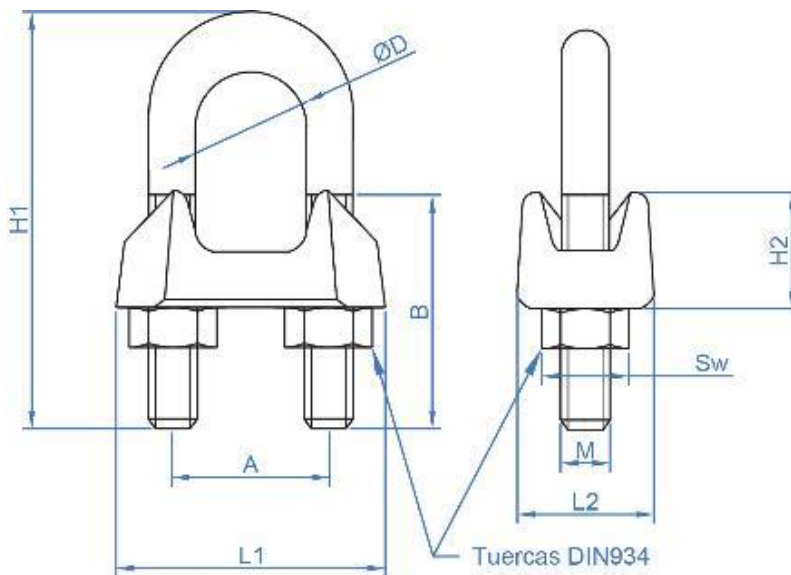



**2.7 SJ-PSA4**

**Single flat wire rope clip, A4 Stainless Steel**



**Material**



A4 Stainless Steel

**Base material**



Cable

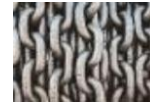

Chain



Rope

**Installation Data**

CODE	CABLE Ø	M	A	B	C	L	Characteristics
SJPSA40403	3	M4	14	14	7,0	20,0	<ul style="list-style-type: none"> <li>- Single flat wire rope clip</li> <li>- A4 Stainless Steel.</li> <li>- Easy installation</li> <li>- A more aesthetic assembly is achieved by reducing the visibility on the joints</li> <li>- Metric nut that locks the cable against a metal plate</li> <li>- Not valid for use as personal protective equipment (PPE)</li> </ul>
SJPSA40504	4	M5	16	17	7,0	22,5	
SJPSA40605	5	M6	16	21	8,5	26,0	
SJPSA40606	6	M6	21	21	9,0	30,0	

**DRAWING**

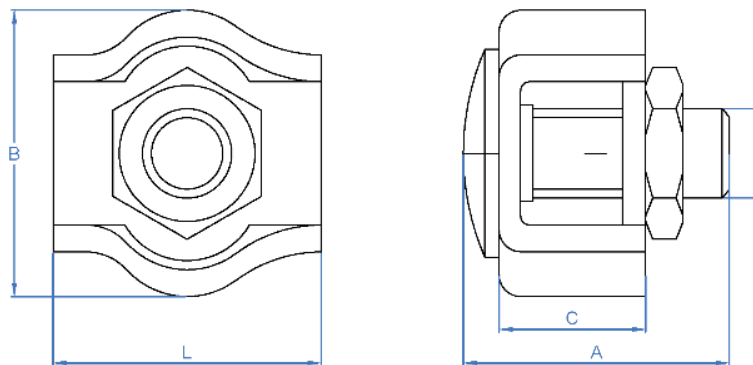

**2.8 SJ-PDA4**

**Double flat wire rope clip, A4 Stainless Steel**



**Material**



A4 Stainless Steel

**Base material**



Cable

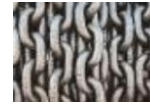

Chain



Rope

**Installation Data**

CODE	CABLE Ø	M	A	B	C	I	Characteristics
SJPDA40402	2	M4	14	13	5,0	37	<ul style="list-style-type: none"> <li>- Double flat wire rope clip</li> <li>- A4 Stainless Steel</li> <li>- Easy installation</li> <li>- A more aesthetic assembly is achieved by reducing the visibility on the joints</li> <li>- Two metric nuts that lock the cable against a metal plate</li> <li>- Not valid for use as personal protective equipment (PPE)</li> </ul>
SJPDA40403	3	M4	14	14	7,0	40	
SJPDA40504	4	M5	16	17	7,0	45	
SJPDA40605	5	M5	16	21	8,5	52	
SJPDA40606	6	M6	23	26	9,0	60	

**DRAWING**

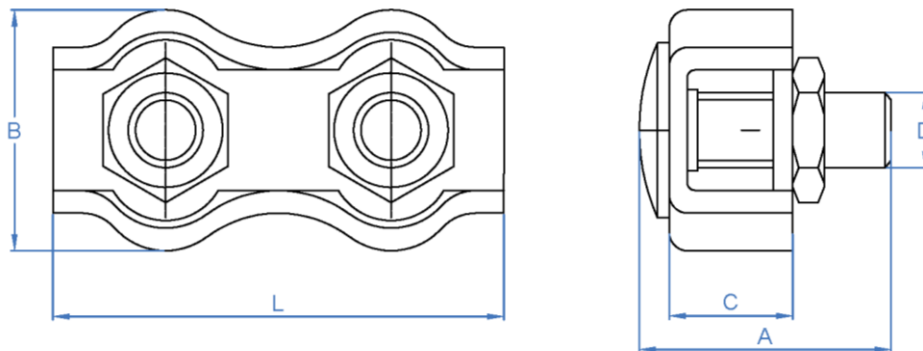

**2.9 TS-GAA4**

**Hook/Ring wire tightener, A4 Stainless Steel**



**Material**



A4 Stainless Steel

**Base material**



Cable



Chain



Rope

**Installation Data**

CODE	M	A [mm]	B [mm]	C [mm]	F [mm]	ØD [mm]	Ød [mm]	I [mm]	J [mm]	G [mm]	(WLL) Axial load capacity in kg
TSGAA405	M5	70	62	50	7	15,5	8,0	7,0	36,0	36,0	50
TSGAA406	M6	110	98	86	9	20,5	10,0	8,0	55,0	55,0	75
TSGAA410	M10	130	107	88	13	31,5	14,0	12,0	67,5	68,0	235
TSGAA412	M12	140	103	83	16	35,0	17,0	15,0	65,0	70,0	320

**Characteristics**

- Hook / ring wire tightener conforming DIN 1480
- A4 Stainless Steel
- Easy installation
- Allows for different applications, great mounting versatility thanks to the combination of hook and ring.
- High quality finish

**DRAWING**

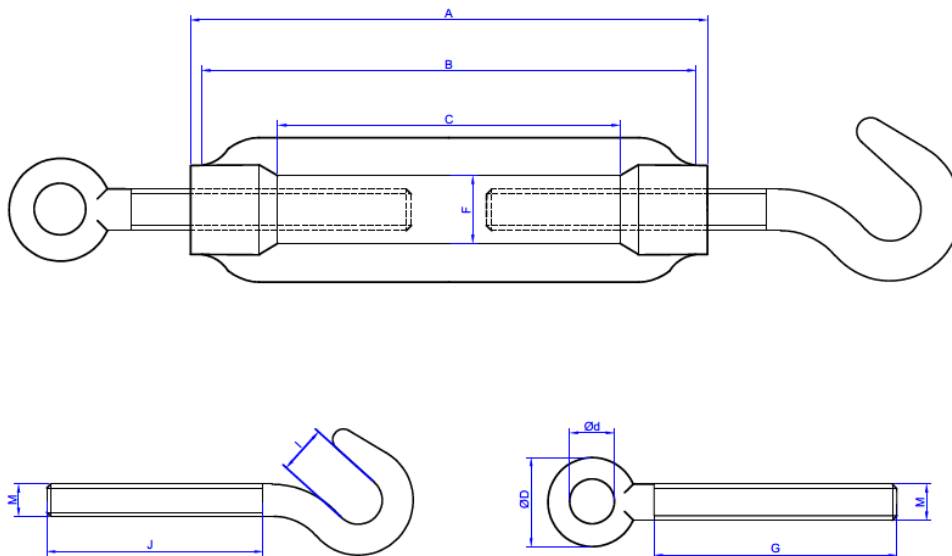

**2.10 TS-AAA4**

**Hook/Hook wire tightener, A4 Stainless Steel**



**Material**



A4 Stainless Steel

**Base material**



Cable

Chain

Rope

**Installation Data**

CODE	M	A [mm]	B [mm]	C [mm]	F [mm]	ØD [mm]	Ød [mm]	G [mm]	H [mm]
TSAA005	M5	70	62	50	7	15,5	8,0	36	58,5
TSAA006	M6	110	98	86	9	20,5	10,0	55	81,5
TSAA008	M8	110	94	80	11	22,5	11,0	55	86,5
TSAA010	M10	130	107	88	13	31,5	14,0	68	106,5
TSAA012	M12	140	103	83	16	35,0	17,0	70	113,0

**Characteristics**

- Ring / ring wire tightener conforming DIN 1480
- A4 Stainless Steel
- Easy installation
- Optimal assembly for applications that require a high level of security and greater tensile strength, which is guaranteed by placing rings on both sides of the wire tightener.
- High quality finish

**DRAWING**

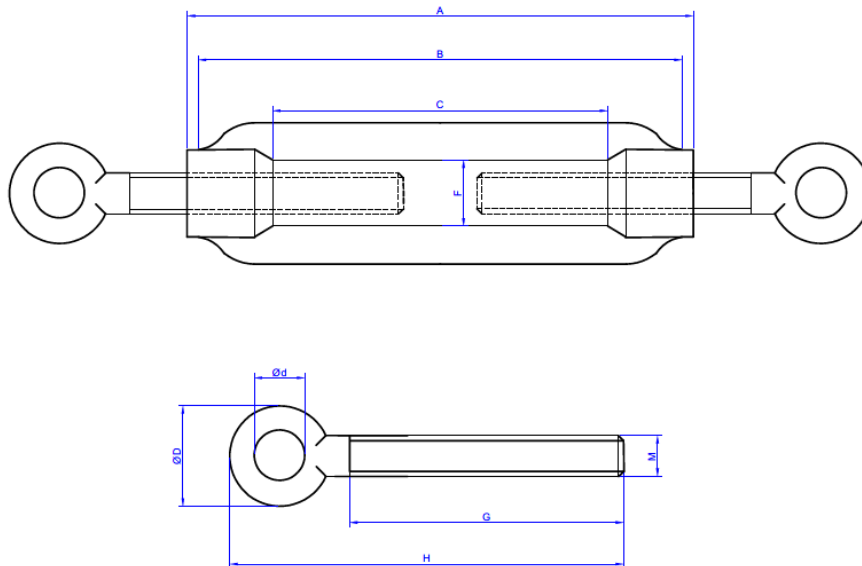

**2.11 TS-GGA4**

**Wire tightener Hook/Hook, A4 Stainless Steel**



Stainless Steel

**Base material**



Cable



Chain



Rope

**Installation Data**

CODE	M	A [mm]	B [mm]	C [mm]	F [mm]	I [mm]	G [mm]	H [mm]	(WLL) Axial load capacity in kg
TSGA05	M5	70	62	50	7	7,0	36,0	63,5	50
TSGA06	M6	110	98	86	9	8,0	55,0	86,0	75
TSGA08	M8	110	94	80	11	9,5	51,5	96,0	100
TSGA10	M10	130	107	89	13	12,0	67,5	119,5	235
TSGA12	M12	140	103	83	16	15,0	65,0	130,5	320

**Characteristics**

- Wire tightener hook / hook conforming DIN 1480
- A4 Stainless Steel
- Double hook allows for quick and easy installation
- Especially for applications where it is necessary to tighten ropes with loops, rig cables, bars, chains, etc. (Faster installation)
- High quality finish

**DRAWING**

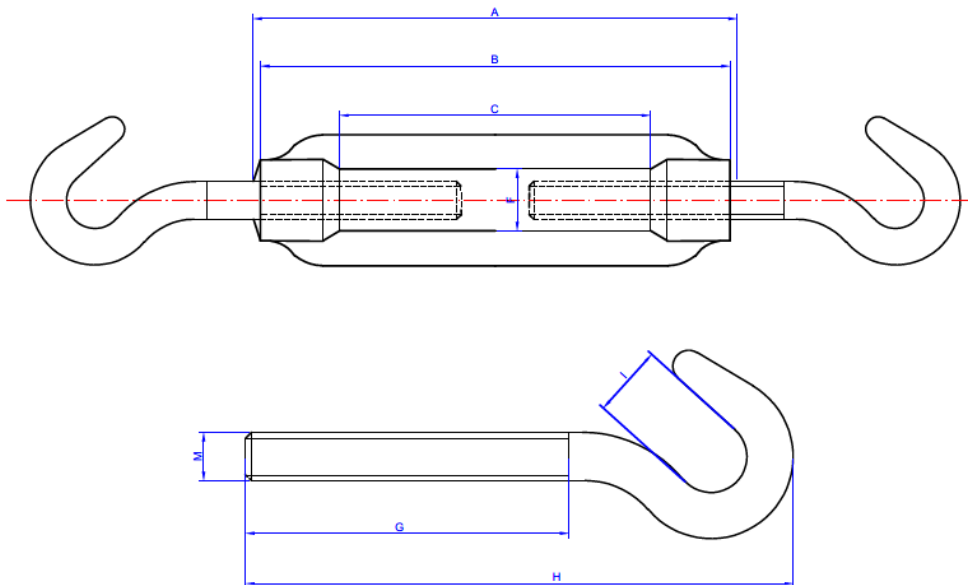

## 4. INSTALLATION PROCESS AND RECOMMENDATIONS

### 4.1 EV-HA4 / EV-MA4

#### Female/male eyebolt, zinc plated

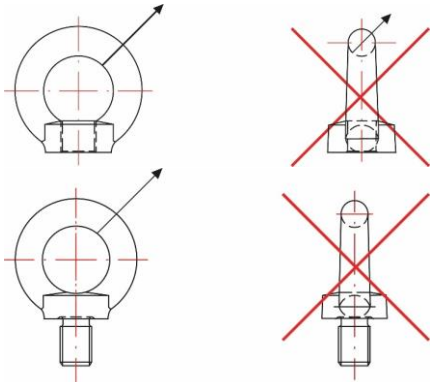

- Before use, check that the ring is correctly seated and without apparent damage.
- Do not use deformed rings or reuse them, they should be replaced if at all possible.
- In case of installing the eyebolt on a through hole, a fully threaded and tightened nut is required on the other side.
- The permissible load values shown in the second column refer to a maximum angle of 45°, and the maximum values shown in the third column refer to a maximum angle of 45° in all directions in respect of the flat ring. The rings should not be loaded from the side (see enclosed images). In cases where there is a specific position to thread the ring, use appropriate washers to avoid unauthorized loads.

### 4.2 GR-A4

#### Straight shackle, zinc plated

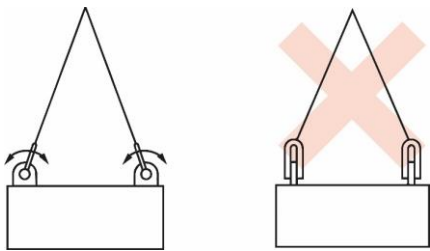

Figure 1

#### 1. Assembly, General:

- Shackles should be inspected prior to use to ensure that:
  - a) Both the body and the shackle pin are of the same size, type and manufacture.
  - b) All markings are readable.
  - c) Body and pin threads are not damaged.
  - d) Body and pin are not twisted.
  - e) Body and pin do not show unnecessary wear.
  - f) Body and pin are free of dents, notches, cracks and corrosion.
- Ensure, if applicable, that the pin is correctly screwed to the head of the shackle, i.e. tighten by hand and then use a pricker or other suitable tool, until the flattened part of the pin seats on the head of the shackle. Make sure the pin is long enough to go all the way into the threaded head, or until the flattened part of the pin hits against the other head.
- In all cases, when the pin is correctly attached to the body of the shackle, the width between the two legs, W, should not be significantly reduced.
- Incorrect pin positioning can be caused by a bent pin, a smaller thread pitch or misaligned holes. In these cases, the shackle must never be used.

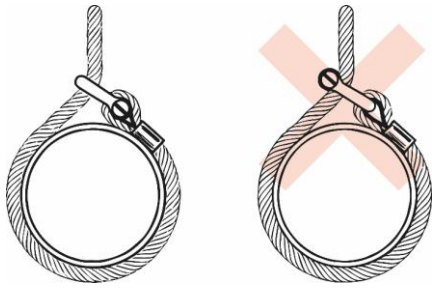

Figure 2

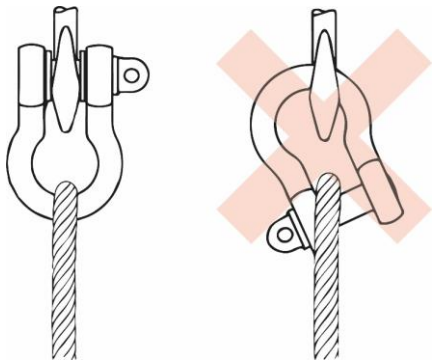

Figure 3

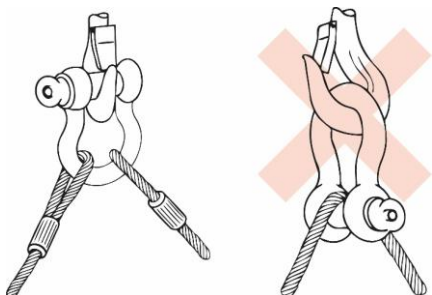

Figure 4

- Never substitute a shackle pin except for one of the same size, grade and specification, as it may not be suitable for the required loads.

2. Use

- The correct type of shackle for each application is selected based on the information provided in the following sections.

- Shackles should not be used in a way that lateral loads are generated. Generally, this means that the shackle body should receive the load along the axis on its centre line (see figure 1).

- When shackles are used with multi-leg slings, the effect of the angle between the legs of the sling should be taken into account. The more the angle opens, the more the load increases on each leg of the sling and therefore on the shackles.

- When a shackle is used to join two slings to the hook of a hoist, the two slings should be joined together on the body of a bow shackle, and the hook placed on the shackle pin. The angles between the slings must not be greater than 120°.

- To avoid loading the shackle with an eccentric load, place spacers on one or both ends of the shackle pin (see figure 2).

- The width between the shackle clamps must not be reduced by welding washers or spacers to the inside faces of the heads, or by closing the clamps, as this will have a harmful effect on the properties of the shackle.

- When a shackle is used to secure the top of a bundle of cables, the load on that shackle is increased by the hoist effect.

- Avoid uses in which, due to movement (e.g., load or cable), the shackle pin might rotate and eventually get loose (see figures 3 and 4).

- In those uses where the pin must be left in place for extended periods of time, or where maximum security is required, an X type pin should be used.

- Avoid uses where the load is unstable (see figure 4).

- Shackles should not be modified, thermally treated, galvanized or coated without the approval of the manufacturer.

- Do not use shackles out of the temperature range -20°C to 200°C without consulting the manufacturer.

- Shackles should not be immersed in acid solutions or exposed to acid fumes or other chemicals without the approval of the manufacturer. Please, be aware that certain manufacturing processes involve acid solutions, fumes, etc. and in these cases advice should be sought from the manufacturer.

- The choice of shackles assumes the absence of exceptionally hazardous conditions. Exceptionally hazardous conditions include offshore activities, lifting people, and lifting potentially dangerous loads such as molten metal, corrosive materials, or fissile materials. In such scenarios, a qualified professional should assess the level of risk and the safe lifting load should be reduced accordingly from the maximum working load.